

# STEEL ART RACK

by Spacesaver®

## INSTALLATION INSTRUCTIONS

**SECTION I**  
INTRODUCTION

**SECTION II**  
CARRIAGE ASSEMBLY

**SECTION III**  
FACE PANELS

**SECTION IV**  
ART RACKS ON CARRIAGES

**SECTION V**  
CANOPY TOPS



SOUTHWEST**SOLUTIONS**GROUP

*business organization systems*

### CAUTION

Spacesaver Recommends:

1. That Safety Glasses be worn during any cutting and drilling operations and grinding.
2. That safety gear such as Hard Hats, Safety Shoes, etc. be worn when required.

## TABLE OF CONTENTS

PAGE NUMBER

REV. XX/XX = LATEST REVISION DATE

### Page No. SECTION I - INTRODUCTION

3	Purpose of Manual
3	Definition of Terms
4	Support Material Required

### SECTION II - CARRIAGE ASSEMBLY

5	Starting Point
5	Wheel Assembly
5	Example Layout
5-6	Wheel section and base layout
6-12	Panels, Tube, Handle, Front and Rear Uprights Preparation and Placement.
13	Final Hardware Tightening
13-14	Stabilizer Tubes
14	Final Wheel Section Adjustment
15	Bumper Placement and Recommended End Stop

### SECTION III - FACE PANELS

16-17	Bracket Positioning
17-18	Carriage Pull
18-19	Panel Orientation

### SECTION IV - ART RACKS ON CARRIAGES

20-21	Without Face Panels
22	With Manual or Mechanical Assist Panels

### SECTION V - CANOPY TOPS for ART RACKS

23	Parts Identification and Installation
----	---------------------------------------

## SECTION I - INTRODUCTION

The purpose of this manual is to describe the steps required for a successful Steel Art Rack installation. The sequence that follows should be strictly followed to avoid the potential for costly errors and/or rework!

### TERMS:

- Wheel Section:** Assembly housing 2 wheels which roll along the rail.
- Anti-tip Hook:** 3 layer hook which engages with a milled groove along the rail aiding in the prevention of carriage tip.
- Guide Bearing Assy:** Cam following bearings which roll along each side of the rail aiding in carriage guidance.
- Clevis Pin:** Removable pin which holds the anti-tip hooks in place.
- Base Spanner:** Attaches to the wheel sections and provides support for the wire mesh panels.
- Gusset:** Material added to the base spanner at each upright tube location to add strength and create a finished appearance.
- Cage Nut:** Self retaining nut inserted into the wire mesh panel frames. Receives the bolts holding the assembly together.
- Wire Mesh Panel:** Forms the area which holds the hanging media.
- Handle:** This part is optional. One may be attached to the front and possibly the rear of dual access systems.
- Upright Tubes:** Stand vertically at the front, rear and center as required to add support for the wire mesh panels and to create a finished appearance.
- Stabilizer Tube:** Square tube bolted to the top of the panels to prevent tipping and carriage spacing.
- Center reinforcement:** Vertical strap welded to the wire mesh panels to add strength.
- Carriage Bumper:** Rubber pads placed in areas where carriages touch to prevent damage.
- Face Panel:** Decorative panel fastened to the front and/or back of each carriage. (optional)
- Carriage:** Mobile Structure to carry Art Racks along rails.
- Mobile Gussets Straps:** To stabilize Art Rack frames on carriages.
- Mobile Gussets Panels:** To stabilize the panel on the carriage.
- DM Channel:** Double moveable cross channels to provide footing for the Art Racks.

**SUPPORT MATERIAL REQUIRED:**

1. Paperwork received from the Production Planning Department.
2. Raised floor installation manual OP-9133.
3. Rail installation manual OP-9438.
4. Steel Carriage installation manual as it relates to guide bearing adjustment and Anti-Tip installation (OP-9616).

**TOOLS:**

- Hex Tool 7/32 (Allen)
- Hex Tool 3/16 (Allen)
- Screwdriver, Phillips & Standard
- 1/4" Drive Universal Joint
- 1/2" Socket (1/4" Drive)
- 1/4" Drive Extension 6"
- Rail Install Tools
- Step Ladder
- 1/4" Drive Ratchet or Socket Drive      -- 5/16" Socket (1/4" Drive)

## SECTION II - CARRIAGE ASSEMBLY

### STEP 1

#### 1.1

The wheel sections will arrive with the anti-tip hook and guide bearing assembly attached. Pull out the clevis pin holding the anti-tip hooks in place. The anti-tip hooks can now swing out of the way, allowing the wheel section to be placed on the rail. Put the clevis pins in a safe place for reinstallation later.

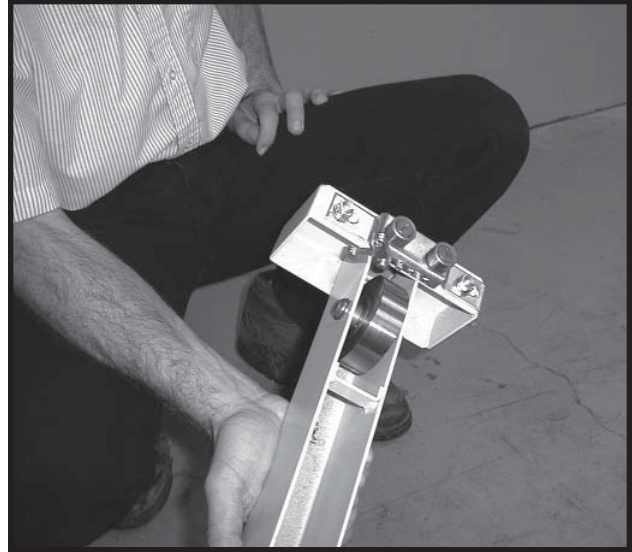

### STEP 2

#### 2.1

This example is a 2 section Art Rack over 3 rails. Place the wheel sections in close proximity to their final location.

NOTE: Guide roller brackets may have to be adjusted slightly to allow proper fit on the rail.

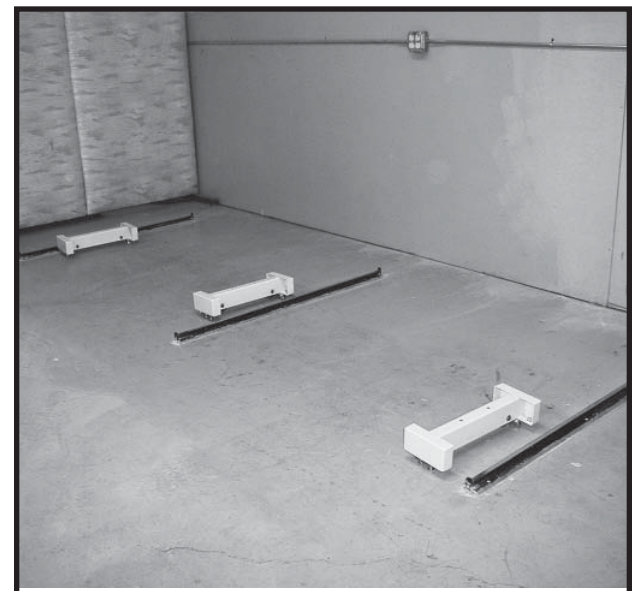

#### 2.2

Place the wheel sections on the rail and bolt the front base spanner to wheel sections 1 & 2. The nuts are welded into the wheel section.

(4)-960182.002 - 3/8" x 1" Socket  
Head Cap Screw

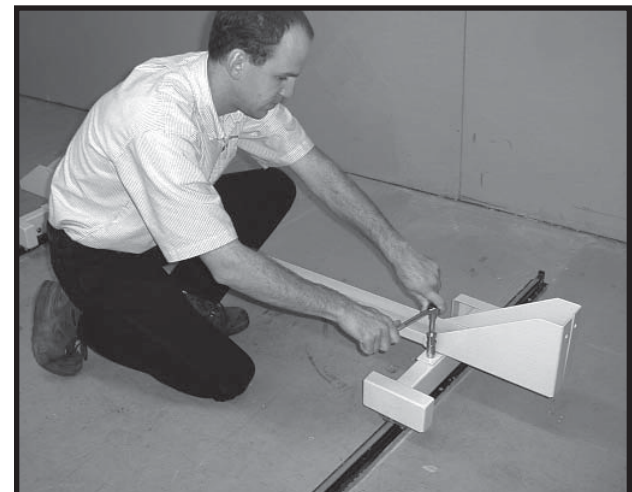

### 2.3

Bolt the rear base spanner to wheel section #3 and place it on the rail.

(2)-960182.002 - 3/8" x 1" Socket Head Cap Screw

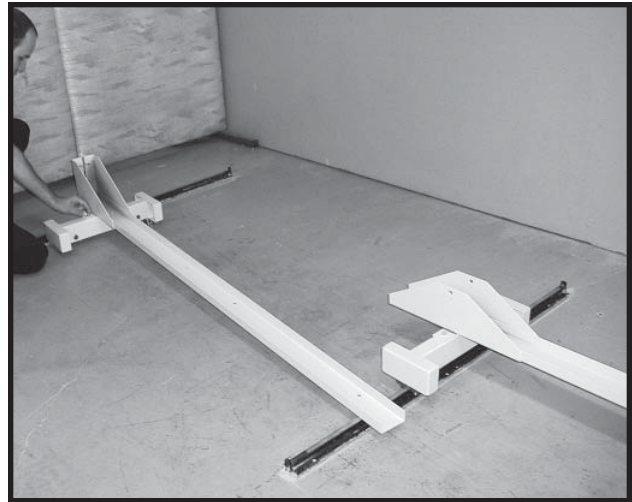

### 2.4

Place the front of the rear spanner into the gusseted support over rail #2. Do not bolt into place at this time.

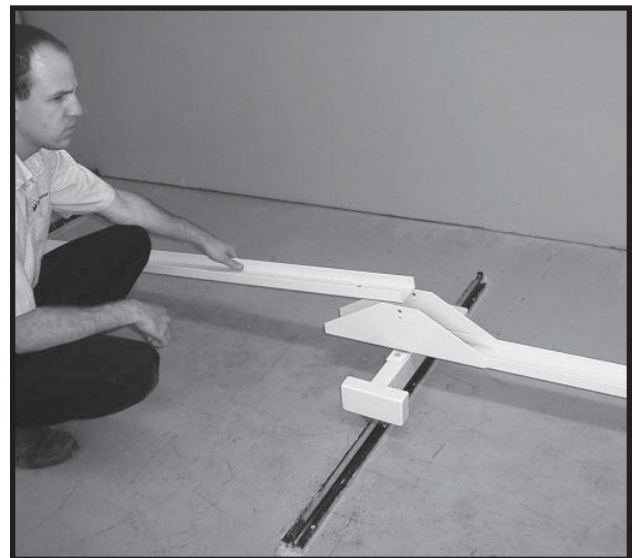

## STEP 3

### 3.1

Cage nuts must be inserted into every elongated hole on the first wire mesh section to be installed. Insert with the nut to the inside of the angle using a screwdriver.

(12)-93040.02 - 5/16" Cage Nut

### ATTENTION!

DO NOT TIGHTEN ANY FRAME HARDWARE UNTIL ALL THE PANELS ARE IN PLACE.

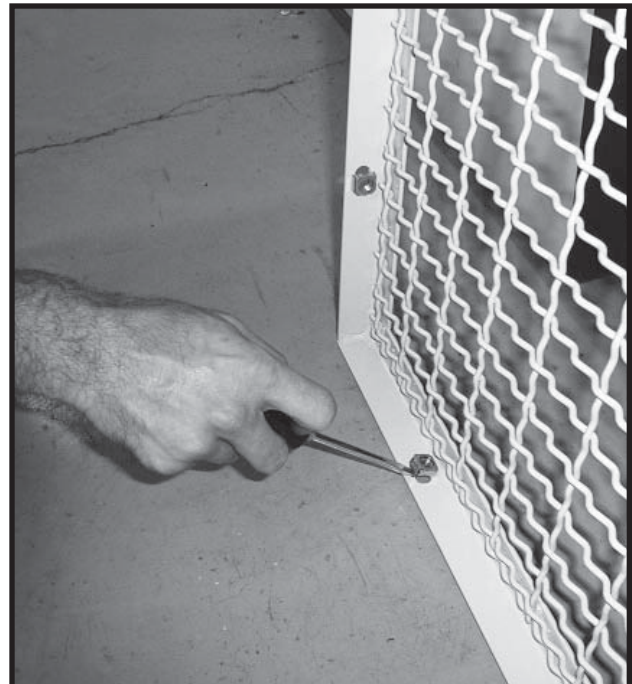

## STEP 4

### 4.1

Place the front right panel onto the base.

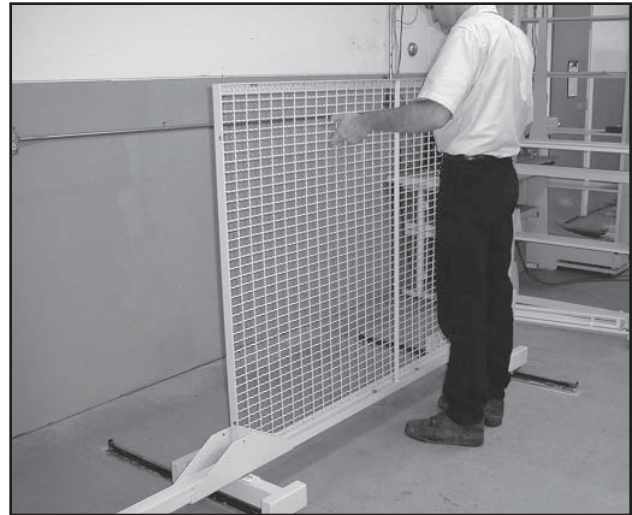

### 4.2

Thread the bolts up through the base into the cage nuts.

(4)-95028.02 - Flange Head Hex Bolt  
5/16" x 7/8"

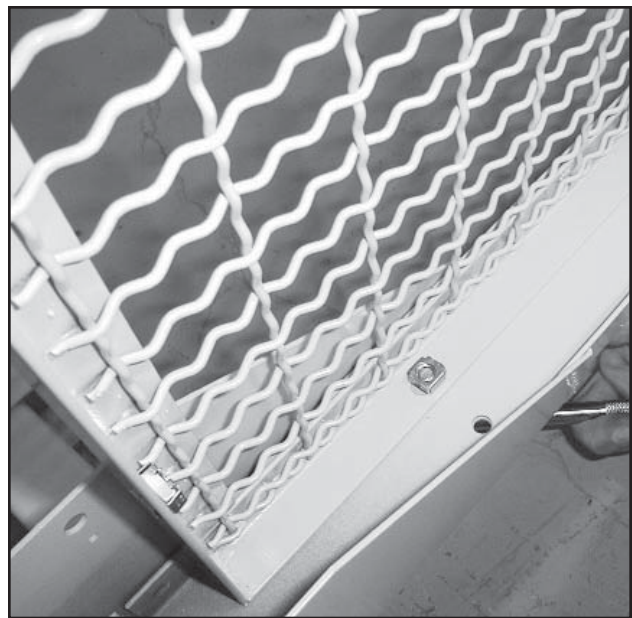

## STEP 5

### 5.1

Place the front left panel back to back with the front right panel and fasten into place just as in step 4. The panels do not fasten to each other, they only bolt to the base. This photo is taken from the rear of the carriage.



## STEP 6

### 6.1

If ordered, locate and install the optional handle. Find the two large clearance holes for the fastening hardware and pass the philips head screws into the threaded handle. This must be done before the upright tube is installed!

(1)-550294.001 - Optional Handle

(2)-960177.001 - Pan Head M8 Screw



## STEP 7

### 7.1

Slide the front upright tube into the clearance opening in the front base gusset. The handle should fall at a convenient elevation.

#### NOTE:

Paint line hanging holes are at bottom of post!

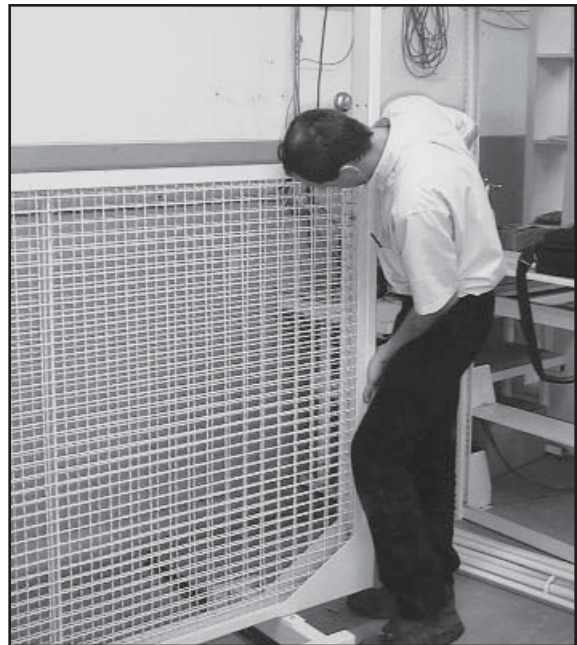

### 7.2

Fasten the upright tube to the front panels using the black socket head bolts. A "T" allen wrench works best for this operation.

(4)-960183.001 - Button Head Cap Screw  
5/16" x 2-1/4"





7.3

The bottom bolts pass through the front base, through the upright tube and into the cage nuts in the panel.



STEP 8

8.1

Prepare the rear right panel by placing cage nuts at all elongated holes except the two that will mate with the front right panel.

(10)-93040.02 - 5-16" Cage Nut

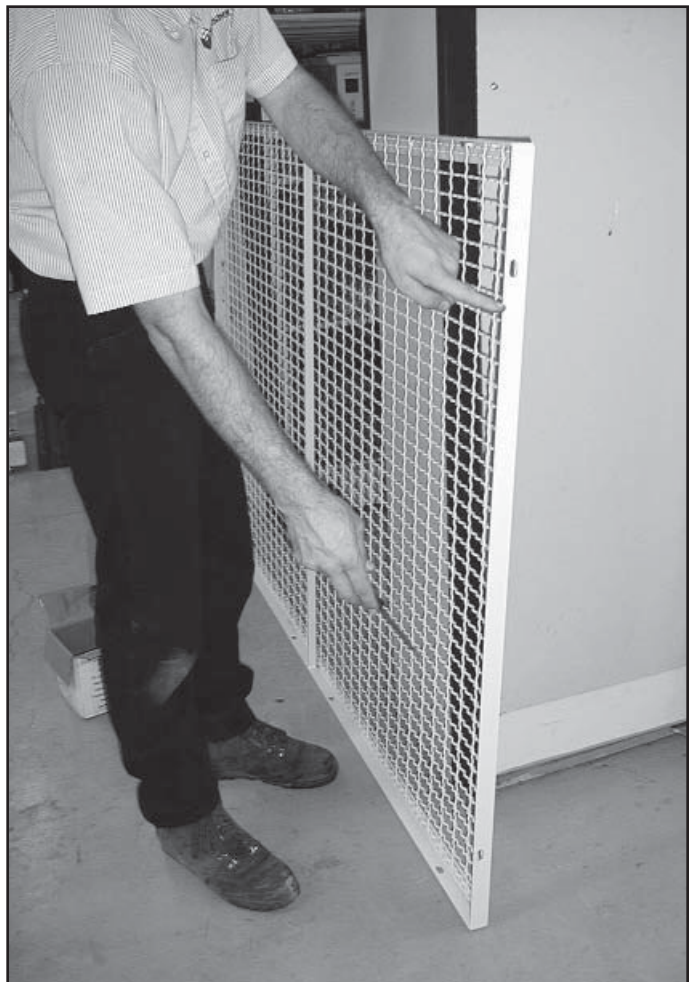

### 8.2

Place the rear right panel onto the base and bolt it into place. Slide the center upright tube between the front and rear panels.

(4)-95028.02 - Flange Head Hex Bolt  
5/16" x 7/8"

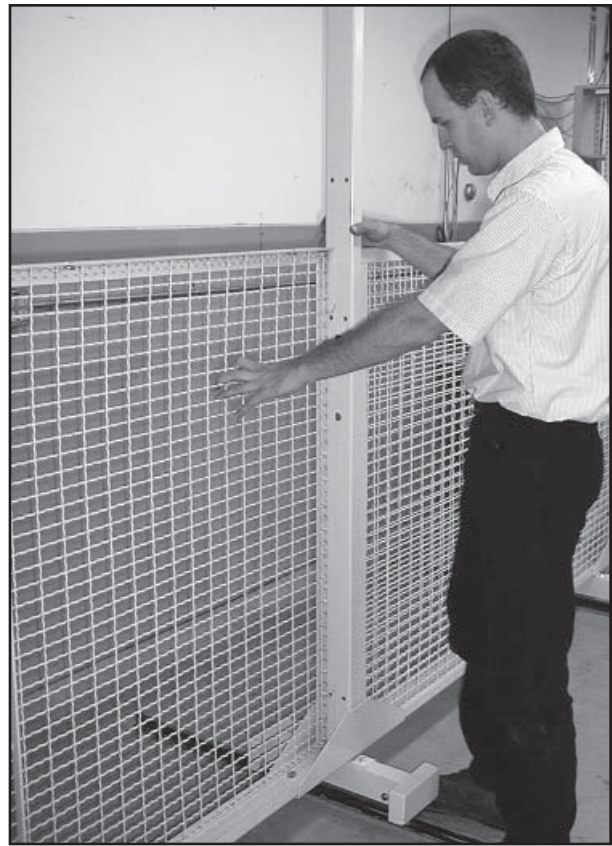

### 8.3

Bolt the rear and front right panels together with bolts passing through the upright tube. Hex head bolts are used here instead of the black socket head type.

(2)-95037.03 - Hex Bolt 5/16" x 2-1/4"

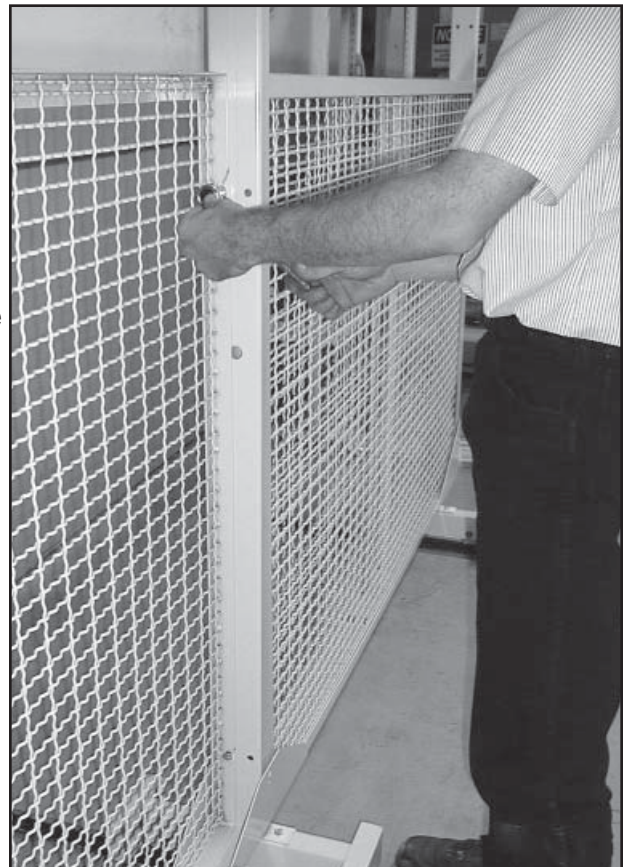

## STEP 9

### 9.1

Prepare the rear left panel by placing cage nuts at all elongated holes except the two that will mate with the front left panel. Place the panel back to back with the rear right and bolt into place just as was done in step 8. We recommend a universal adapter to accommodate passing the socket through the wire mesh of the panel.

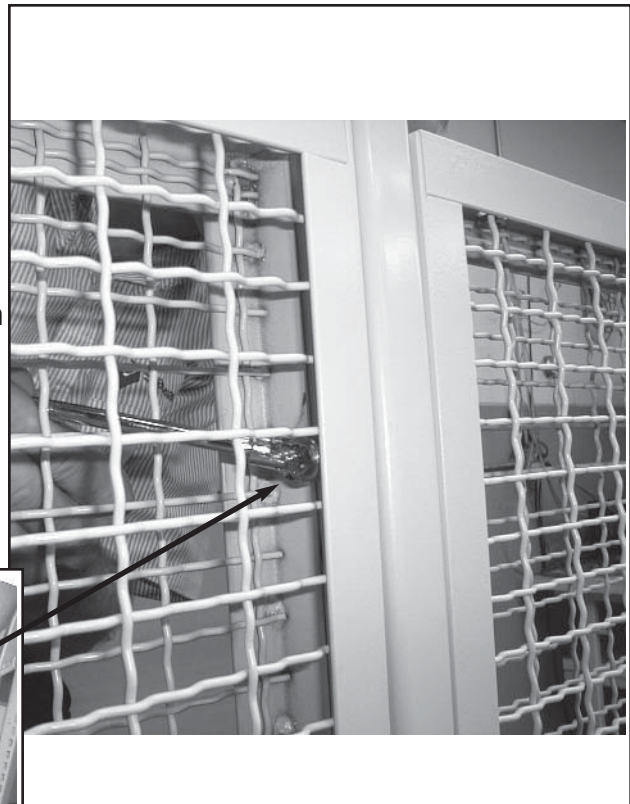
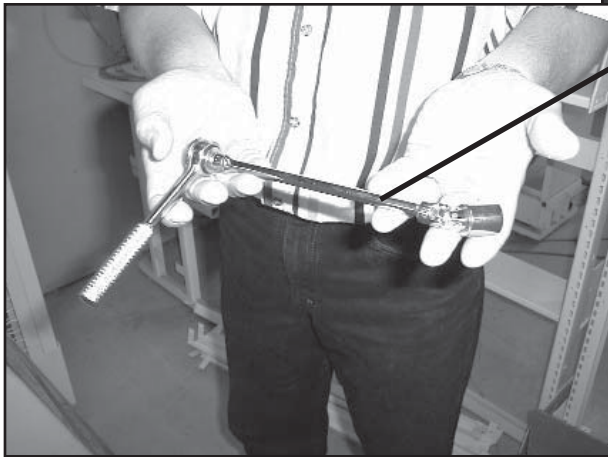

- (10) -93040.02 - 5/16" Cage Nut
- (4) -95028.02 - Flange Head Hex Bolt 5/16" x 7/8"
- (2) -95037.03 - Hex Bolt 5/16" x 2-1/4"

## STEP 10

### 10.1

Slide the rear upright tube into the clearance opening in the rear base gusset.

NOTE: If the system will have rear access an optional handle may be provided. Install the handle before the rear upright tube.

OPTIONAL(1) - 550294.001 - Optional Handle  
(2) - 960177.001 - Pan Head M8 Screw



10.2

Fasten the rear upright tube to the rear panels.

(4)-960183.001 - Button Head Cap Screw  
5/16" x 2-1/4"



## STEP 11

11.1

Prepare the upper front right panel by inserting cage nuts at the front and rear elongated holes. (4 total) Place one additional cage nut in the top opening just forward of the center reinforcement bar. This cage nut will receive a bolt for an overhead stabilizer.

(5)-93040.02 - 5/16" Cage Nut



## STEP 12

### 12.1

Place the remaining upper panels on top of the lower panels and fasten into place. Plan ahead where to insert the cage nuts, this can be a little confusing. The cage nuts for the rear stabilizer are placed just to the rear of the reinforcement bar in the panel. Use two people to lift the upper panels into place.

(11)-93040.02 - 5/16" Cage Nut

(8)-960183.001 - Button Head Cap Screw  
5/16" x 7/8"

(16)-95028.02 - Flange Head Hex Bolt  
5/16" x 7/8"

(4)-95037.03 - Hex Bolt 5/16" x 2-1/4"

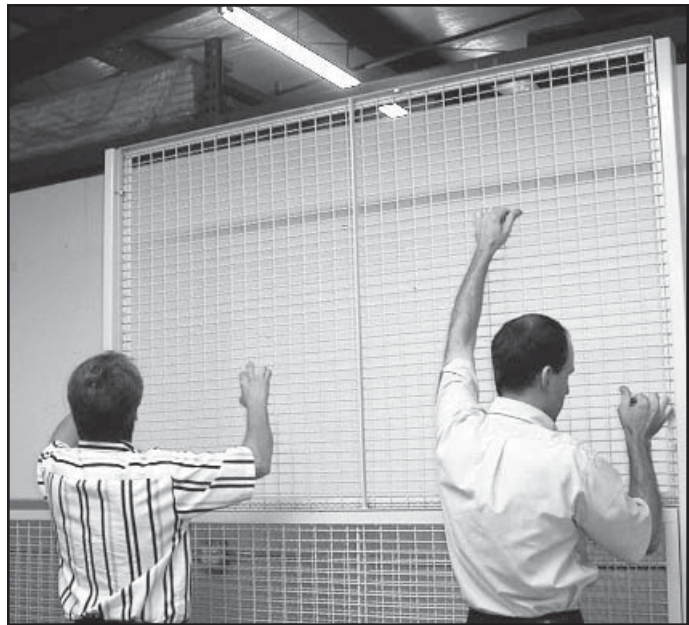

## STEP 13

### 13.1

Tighten all fasteners. Start at the bottom and work your way up.

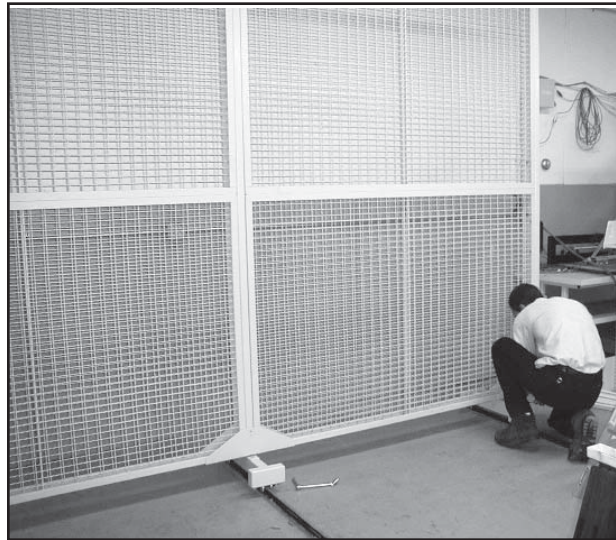

## STEP 14

### 14.1

Locate the overhead stabilizer tubes. Plastic ends are pressed into them.

(2)-290840.001/290840.002 - Overhead  
Stabilizer Tube

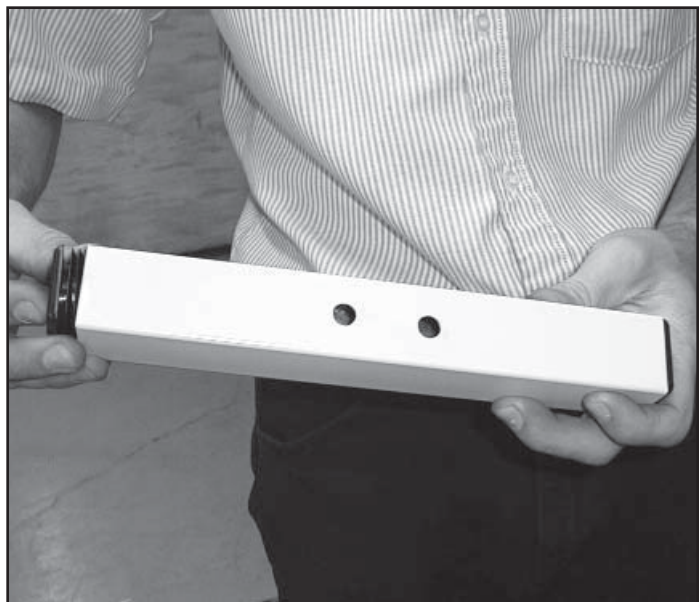

## 14.2

Fasten the overhead stabilizers into place on the top at the front and the rear. Place the channel stiffener at each mesh panel juncture along the top. Install cage nuts and hex bolts as shown earlier.

(4)- 95037.03 - Hex Bolt 5/16" x 2-1/4"

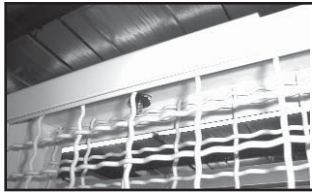

## STEP 15

### 15.1

There is a pre-drilled hole on both sides of the center gusseted support. Place a self drilling and threading TEK screw at both locations.

(2)-96060.01 - #12 X 1.0 Tek's Screw



## STEP 16

### 16.1

Return to the wheel sections to make any necessary guide roller adjustment and to set the anti-tip hooks. Check the Steel Carriage installation manual (OP-9516) for more detail on these steps.

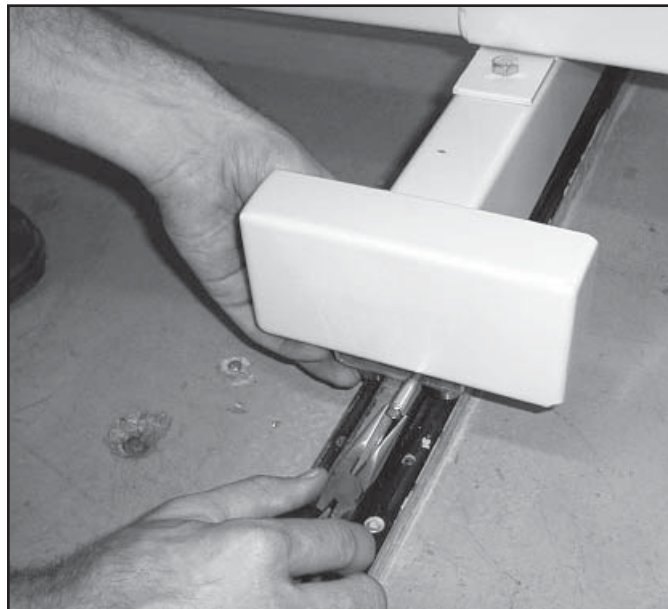

## STEP 17

### 17.1

See the following illustration for carriage bumper installation. Most layouts will conform to the nesting carriage configuration shown. If carriages do not nest, then a bumper must be installed directly to the ends of the wheel sections. Place bumpers on both sides of the front and rear wheel sections on the left most carriage. Place bumpers on the right side of the front and rear wheel section on all other carriages. (See Illustration.)

## Nesting Carriage Bumpers

**Note: Non Nested Carriages require bumpers installed to one side of mating wheel sections.**

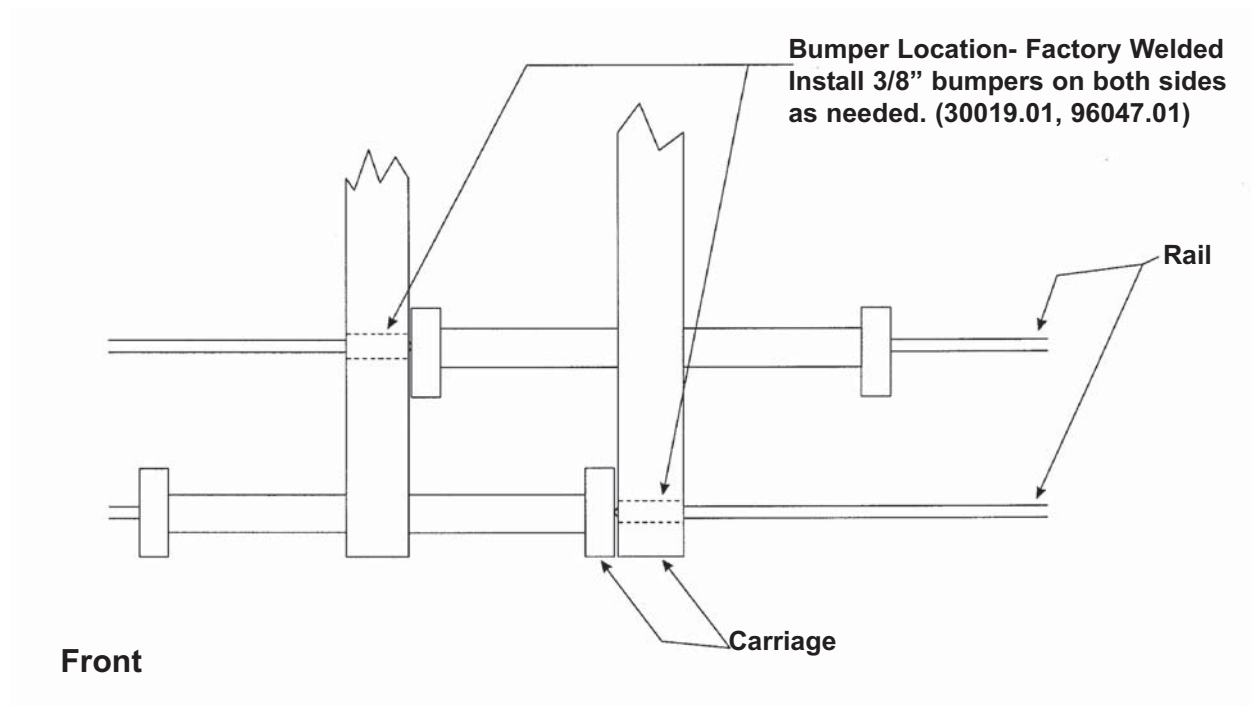

### Non- Nested Drilling Required:

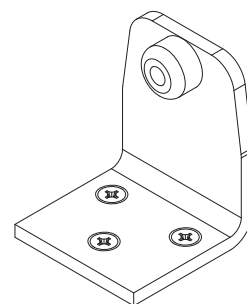
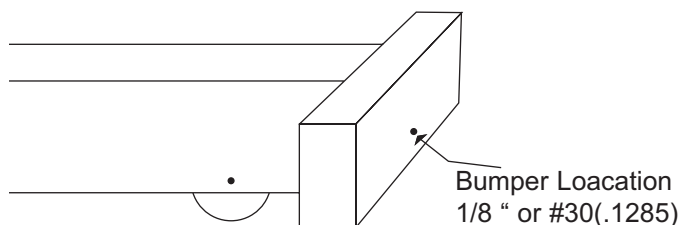

400973.001  
Angle Endstop  
(mounted to floor) B Rail, B  
Anti-Tip, L Rail, or T Rail.

## STEP 1

### 1.1

The bracket should be oriented to the Art Rack frame as shown.



### 1.2

Fasten the panel brackets with the Tek screws provided. (part number 96102.01) These screws drill and thread themselves into the metal frame. A 3/8 inch driver head is required. Use the bracket itself as a template for hole location. The bracket will self align with the frame.





### 1.3

Notice the location of the brackets. These dimensions are not critical but should be consistent from carriage to carriage. The bottom bracket rests directly on the gusset of the frame, the middle bracket should be centered vertically and the top bracket should be about 6 inches from the top.

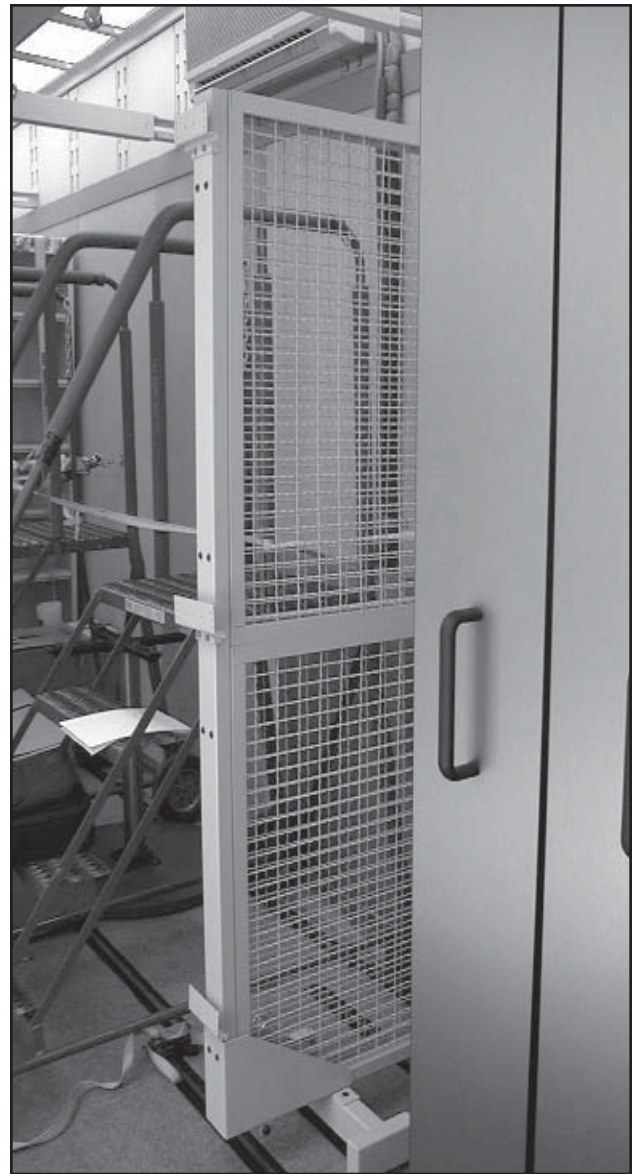

### STEP 2

#### 2.1

The face panel may be provided with a pull. It will consist of the pull itself, 2 washers and 2 self locking machine screws.



## 2.2

If the face panels are to receive pulls the required 2 holes will be factory drilled. Pass the screws and washers from behind the panel and thread into the pull.



## STEP3

### 3.1

Panel elevations **MUST** be consistent from carriage to carriage. Since the floor configuration may vary, use a fixed point on the carriage as a bench mark. The bottom bracket which rests on the gusset makes a good bench mark. Set the panel bottom at a consistent dimension lower than the bracket. Center the panels on the upright post.



**NOTE:**

The face panels on each end of the system may be wider than the others. These panels must be offset rather than centered.

**NOTE:**

See the Face Panel Installation Instructions manual (OP-9531) for detail regarding alignment. Panels must be plumb and evenly spaced!



## SECTION IV - ART RACKS ON CARRIAGES

Note: The following information deals only with the steps involved when attaching assembled Art Rack frames to mobile carriages. The 2 methods outlined below are; Art Racks to carriages without face panels and with face panels. Mechanical Assist types are also available and are installed like the “with face panels” version. The additional steps of connecting and adjusting the drive are required. See installation manual OP-9531 titled “Face Panels and Back Panels” for guidance relative to these steps.

### Note:

Optional drop in panels may be provided to hide the open space on the floor of the carriage. If so it is critical that the Art Rack frames be centered exactly on the carriages. Carriages will generally be 18 or 21 inches in width.

### Illustration 1:

Art Rack frames may be attached to mobile carriages as shown. They must be anchored to the carriages, braced with gusset straps and spaced with overhead tubes.

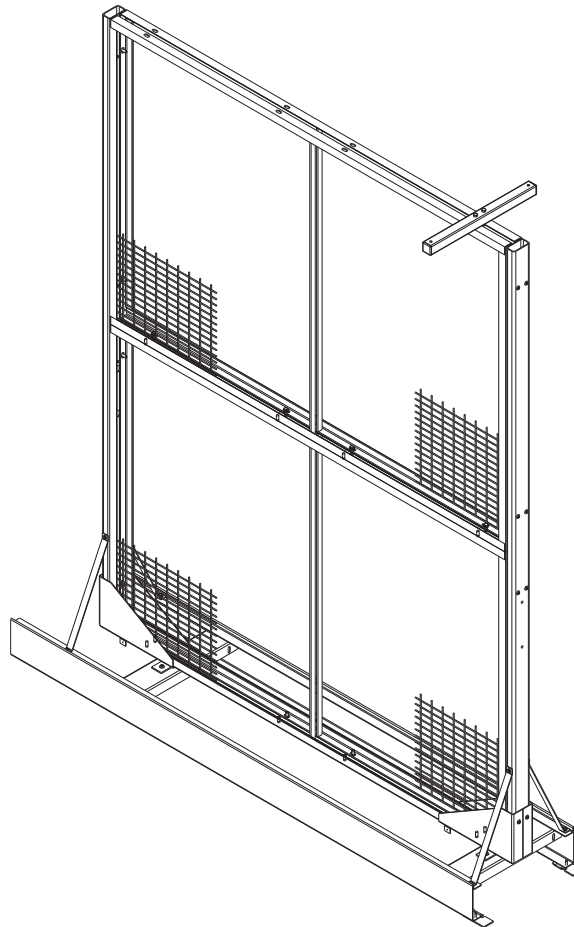

**Illustration 2:**

Center the Art Rack frame **exactly** on the carriage. Use the holes in the fastening strap as a template to drill the 3/8 inch holes through the DM channels below.

- 960182.003 3/8-16 x .750" button head cap screw
- 93005.02 3/8-16 flange locking
- 960182.003

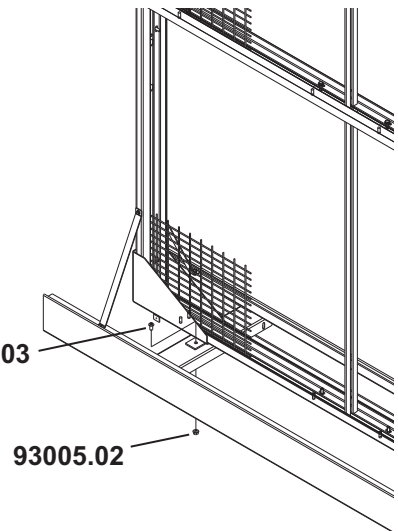

**Illustration 3:**

Fasten the gusset straps to the carriage lips and the Art Rack frames with tek screws.

- 96102.01 tek screw
- 401070.001 gusset strap for 18 inch wide carriage
- 401070.002 gusset strap for 21 inch wide carriage

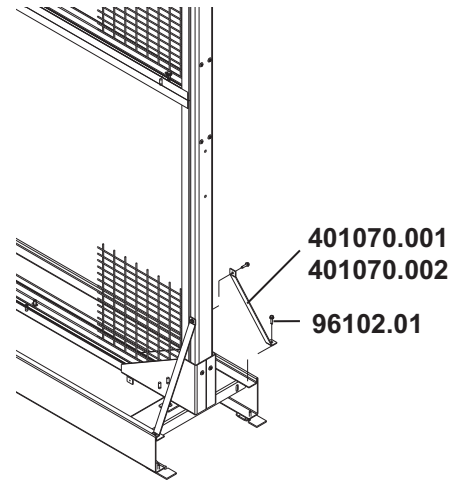

**Illustration 4:**

Center and fasten the spacer tube to the frame top.

- 290840.005 for 18 inch wide carriage
- 290840.006 for 21 inch wide carriage
- 95037.03 5/16 - 18 x 2.25" hex bolt

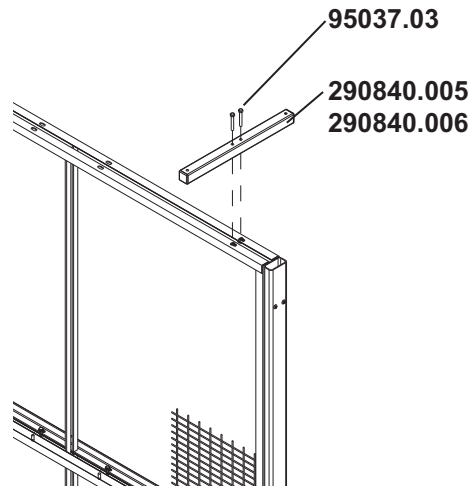

**Illustration 5:**

When either manual or Mechanical Assist panels are used, this array of gussets and brackets must be used.

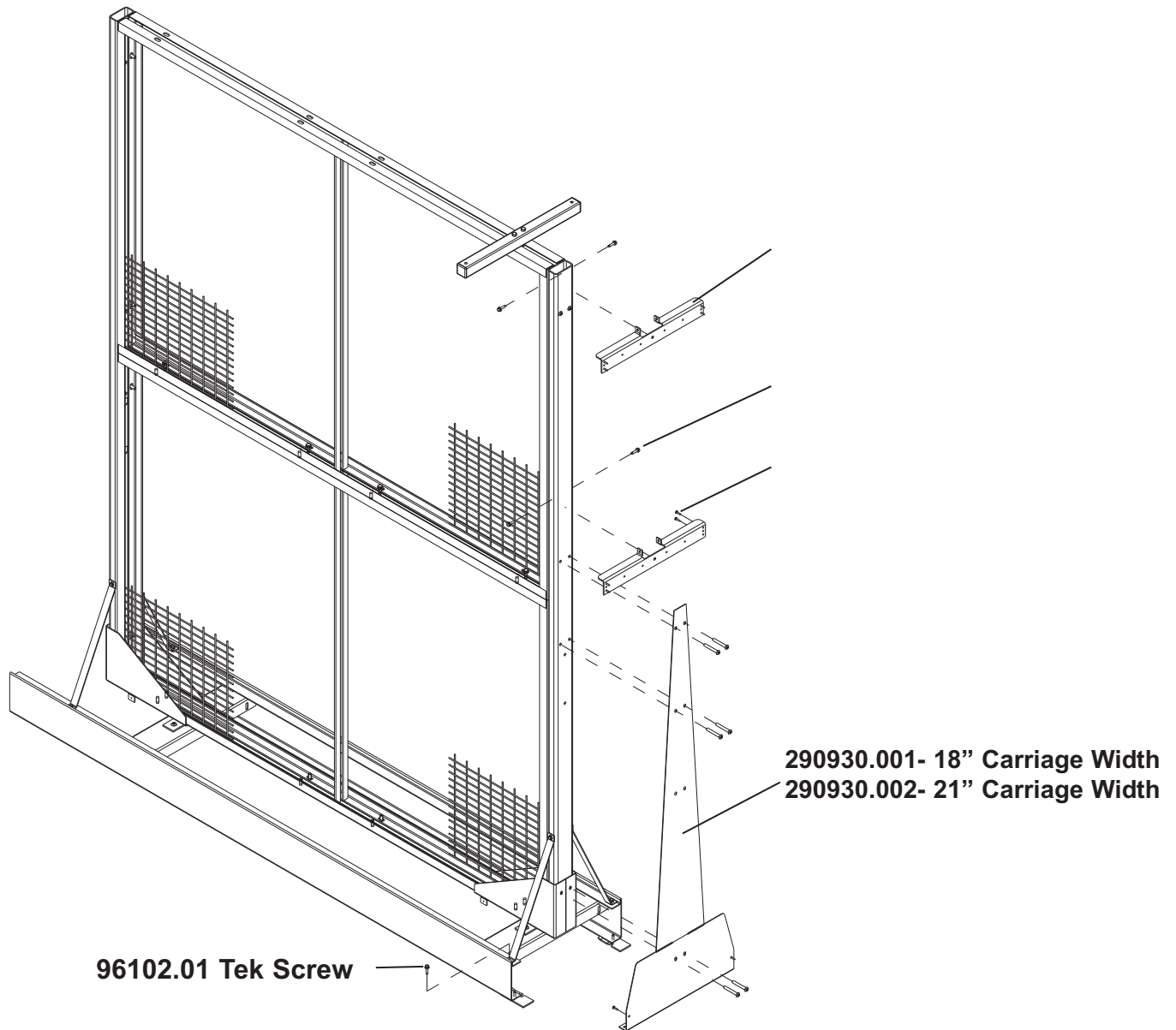

## CANOPY TOPS for ART RACKS

Attachments 6 &7:

Canopy top for Art Rack is attached using the Bracket 402246.002 and appropriate Tek Screws.

Attach the bracket to the Canopy top Weldment and then place the top on the art rack and attach using 96060.01 as indicated.

21" Canopy Top is shown the same procedure would be used for other size canopy tops.

- 402246.002 - Bracket -Art Rack, Panel Mount
- 96117.01 - Screws - TEKS, Pan Head Cross Recessed
- 96060.01 - Screw - TEKS, Hex Washer Head #12
- 340565.xxx - Canopy top cover Weldment Plain 21"

