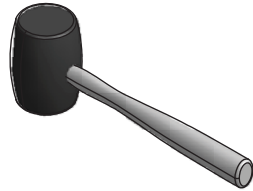


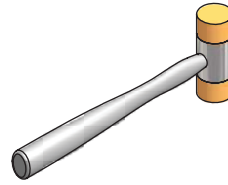
# 4POST ASSEMBLY INSTRUCTIONS

## TOOLS REQUIRED FOR ASSEMBLY



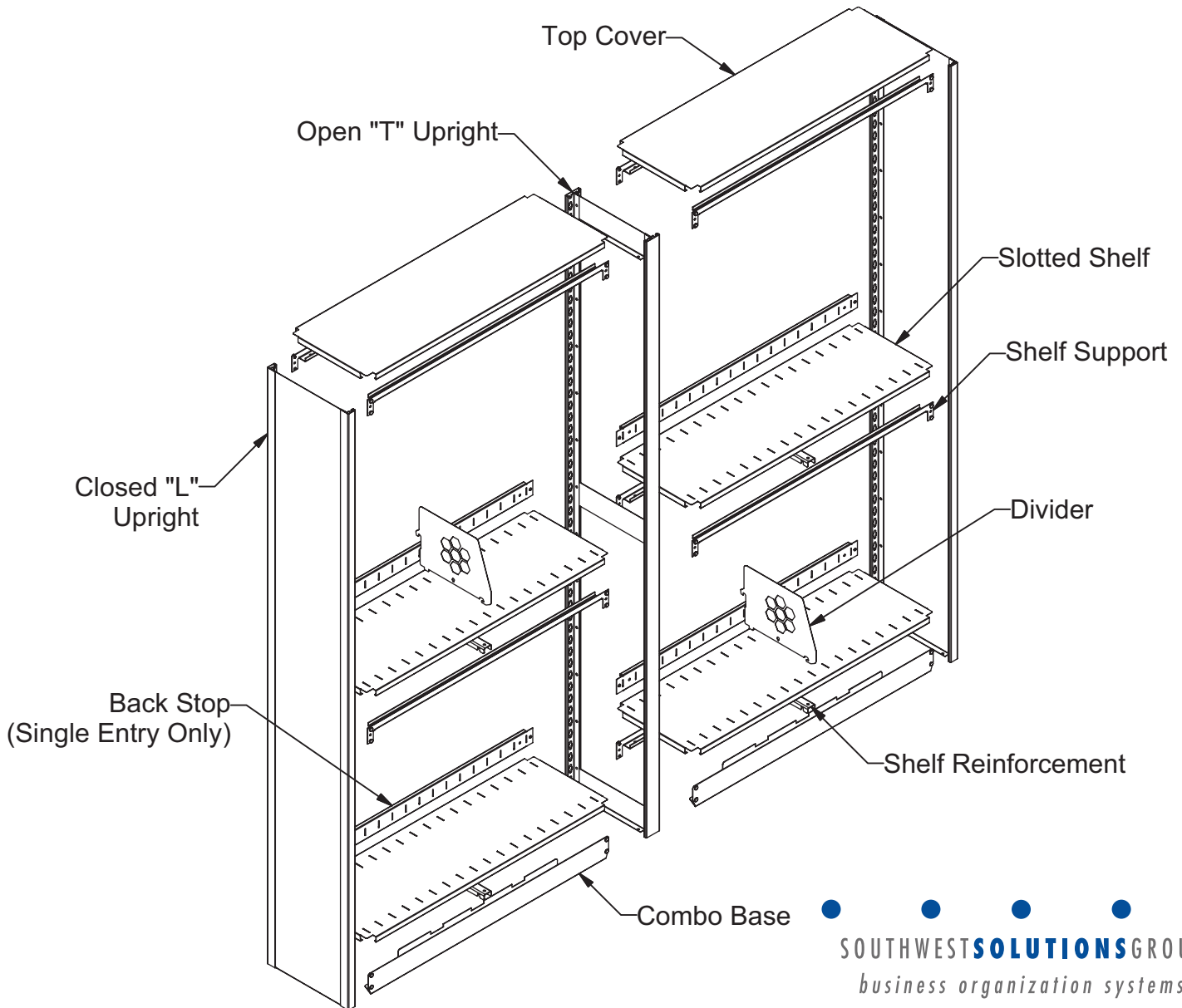
Rubber Mallet

OR



Plastic Tip Hammer

## PARTS REQUIRED FOR ASSEMBLY OF SINGLE ENTRY ROW OF SHELVING

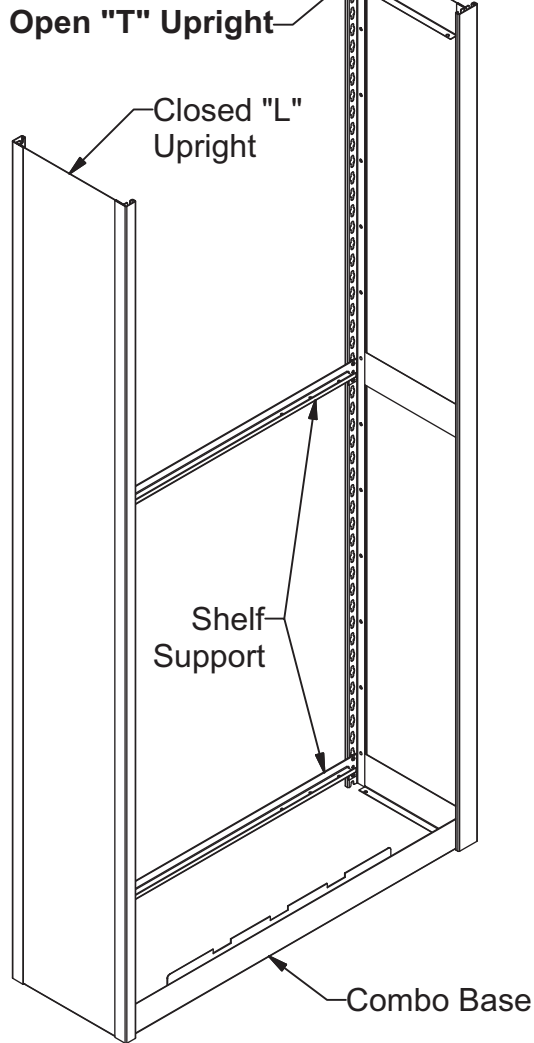


**SOUTHWEST SOLUTIONS GROUP**  
*business organization systems*

# 4POST ASSEMBLY INSTRUCTIONS

## 2" Combo Base

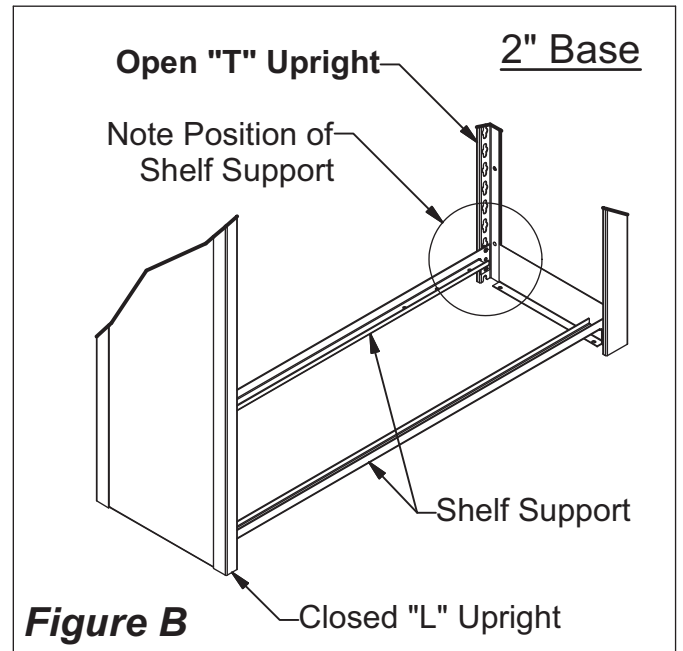
(Typical Configuration)



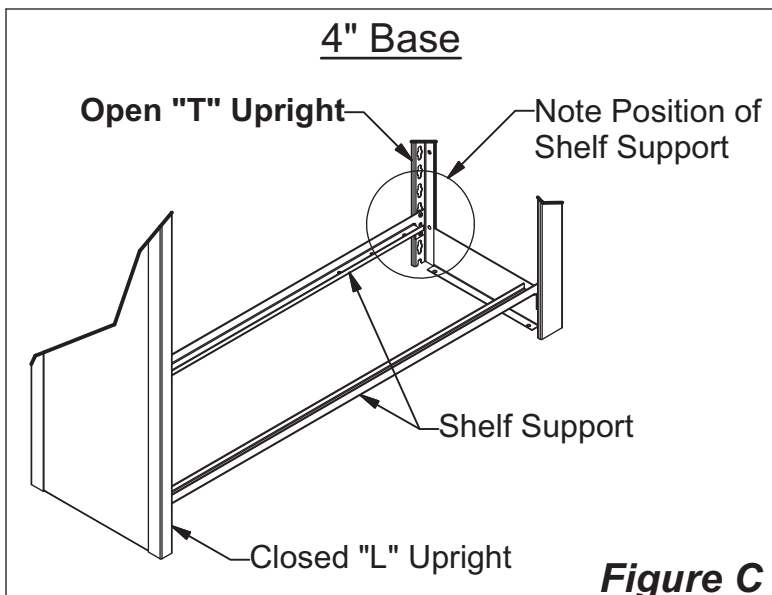
**Figure A**

**Step 1:** Temporarily mount a Shelf Support at chest height between a Closed "L" Upright on left and an Open "T" Upright on right to hold them in position (*Figure A*). Rivets of Shelf Support fit into keyholes on Uprights. Use a Rubber Mallet or Plastic Tip Hammer to tap Shelf Support into bottom of keyholes.

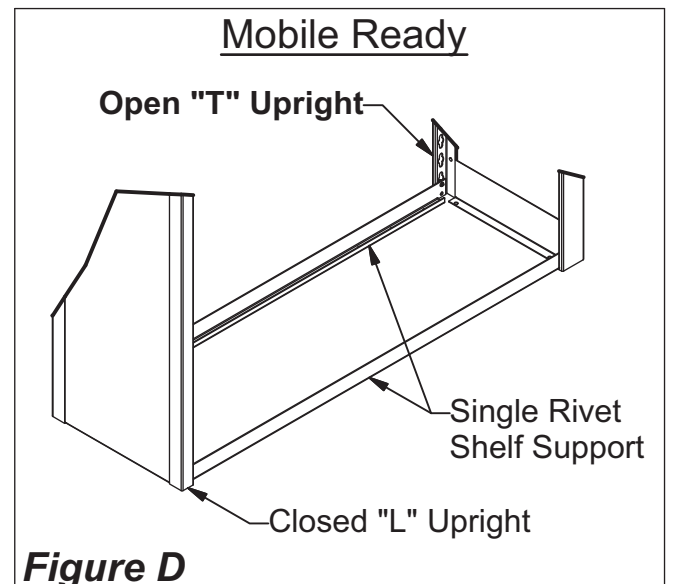
**Step 2:** Depending on configuration ordered, bottom components will be assembled in one of four ways below. Refer to *Figures A, B, C & D*.



**Figure B**

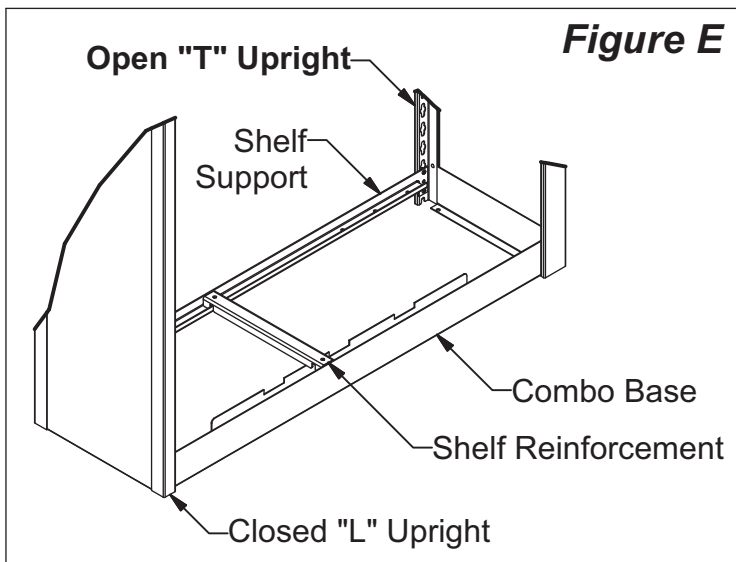


**Figure C**



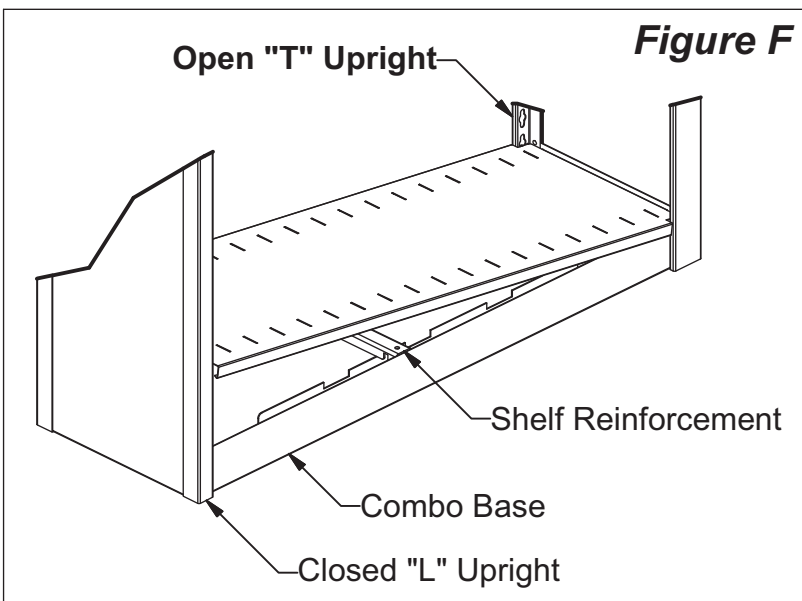
**Figure D**

# 4POST ASSEMBLY INSTRUCTIONS



**Step 3:** If required (see **Table 1**), install Shelf Reinforcement(s) as shown in *Figure E*.

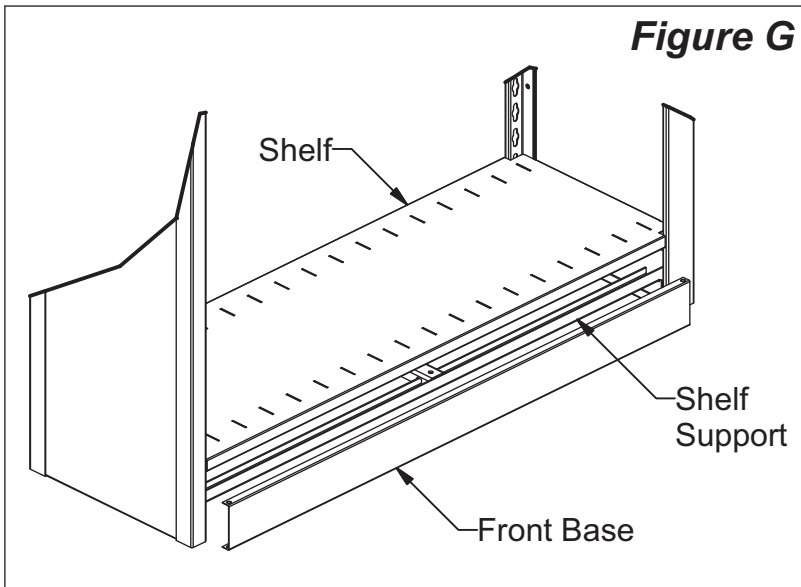
Depth of Shelving	No. of Shelf Reinforcements
12"	None
15"	None
18"	Two



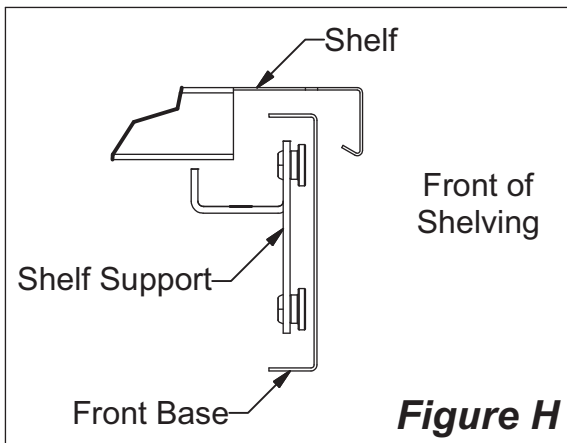
**Step 4:** Install Shelf by tilting as shown in *Figure F*. It should then lay flat on Combo Base & Shelf Support.

# 4POST ASSEMBLY INSTRUCTIONS

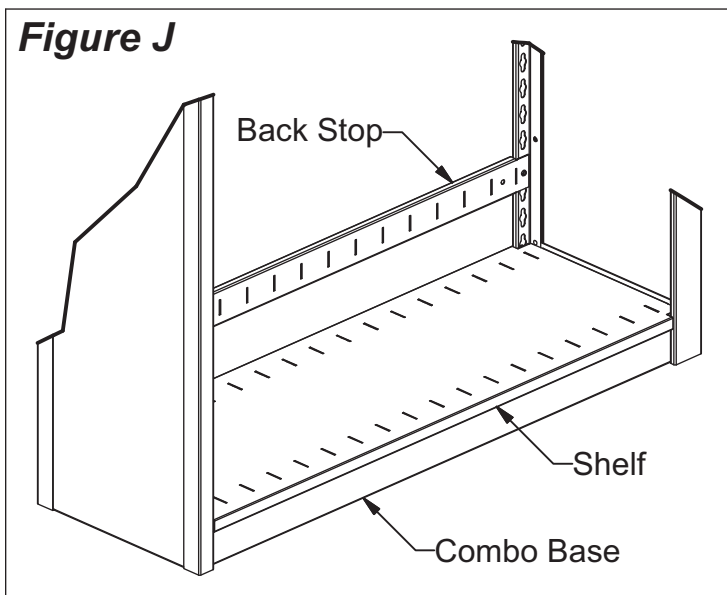
**Figure G**



**Step 5: For Front Base only!** Position Front Base as shown in *Figure G* by lifting up Shelf enough to fit top flange of Front Base between Shelf and Shelf Support. (also refer to *Figure H*)



**Figure J**



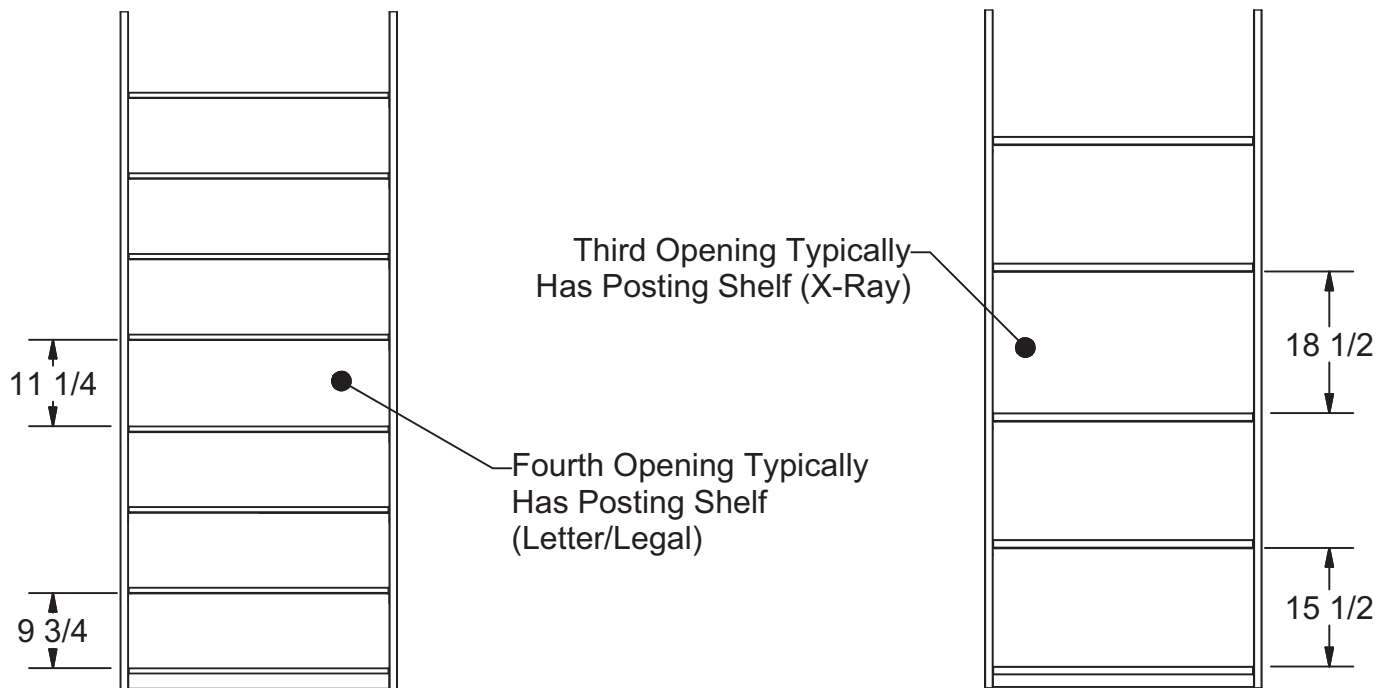
**Step 6:** Install Back Stop for bottom Shelf. Count up three complete keyholes from top of Shelf and place rivets located on each end of Back Stop in these keyholes. (see *Figure J*)

# 4POST ASSEMBLY INSTRUCTIONS

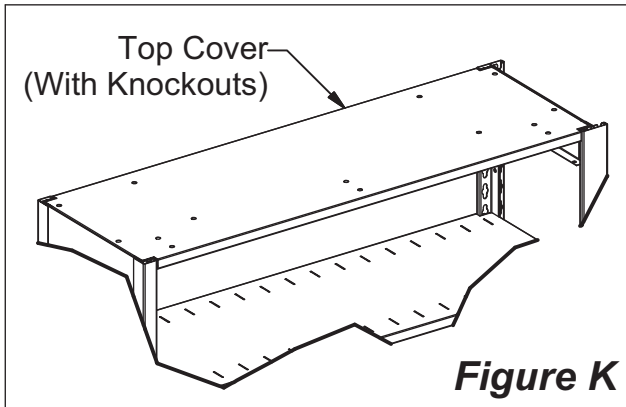
**Step 7:** Install remainder of Shelf Supports, Shelves, & Shelf Reinforcements (if required) as previously shown. Keep in mind your installation may be different, as Shelf spacing varies from job to job.

*Typical Clear Openings  
for Letter/Legal Shelving*

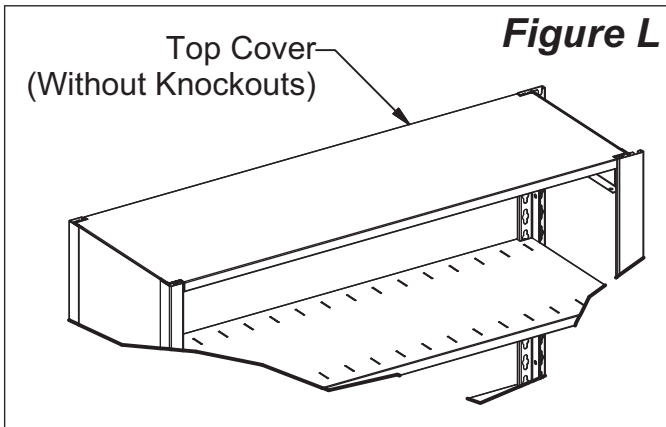
*Typical Clear Openings  
for X-Ray Shelving*



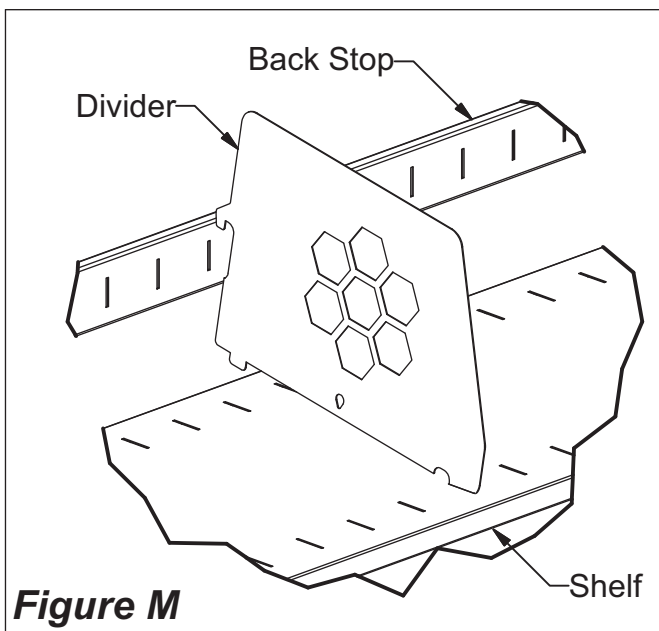
# 4POST ASSEMBLY INSTRUCTIONS



**Note:** Top Shelf does not require Shelf Reinforcements. Depending on components ordered, Top Cover may or may not have knockouts in it. *Figure K* shows a Top Cover with knockouts & *Figure L* shows a Top Cover without knockouts. Top Cover with knockouts is only necessary when Unit is being used on a Mobile System.

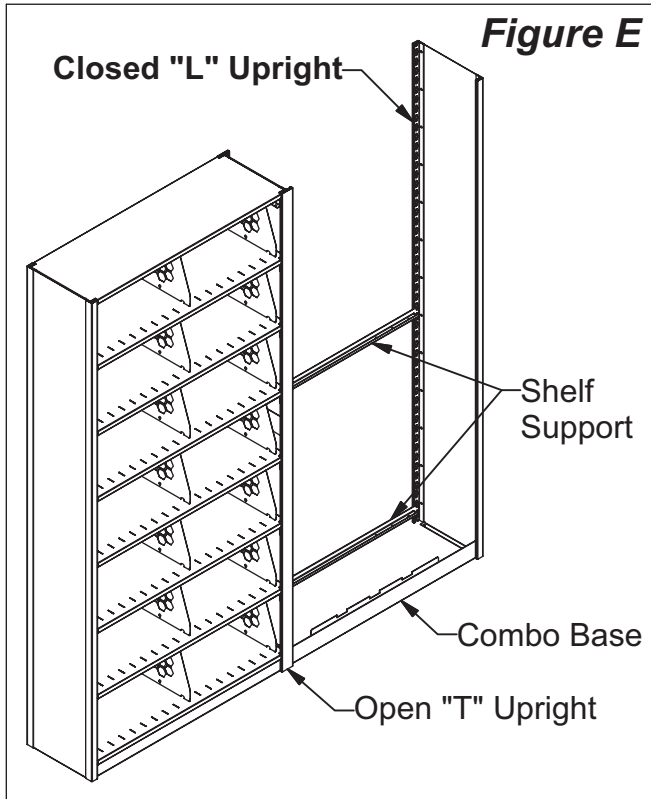


**Step 8:** Install Top Cover the same way Shelves were installed. Shelf Supports for Top Cover should be positioned in top two most keyholes.



**Step 9:** To install Divider, it must be tilted up in back for hook in front to be inserted into front slot. Then simply tilt back down into slots in back and Back Stop. (see *Figure M*)

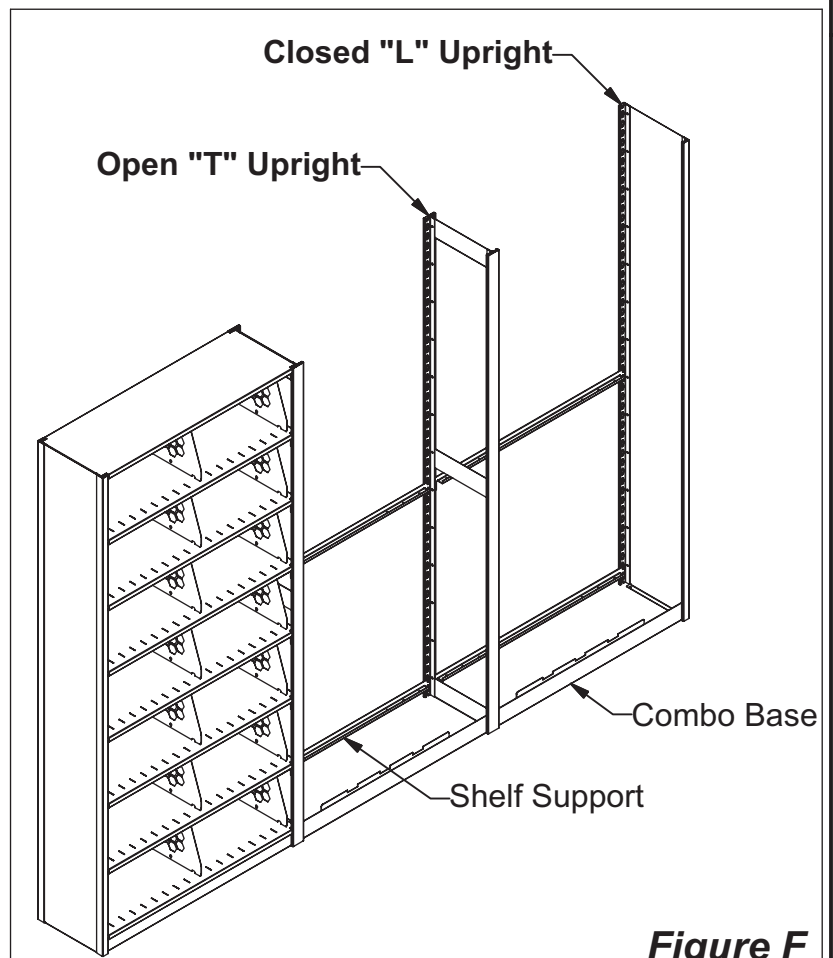
# 4POST ASSEMBLY INSTRUCTIONS



**NOTE:** If your section consists of two or more units (*Figure F*), proceed to **Step 10b** at the bottom half of this page. If your section consists of just two units (*Figure E*), continue here at **Step 10a**.

**Step 10a:** Position a Closed "L" Upright to the right and install Combo Base & Shelf Supports the same as **Steps 1** and **2** (*Figure E*).

**Step 10b:** Repeat **Steps 1** and **2** but, substitute an Open "T" Upright for a Closed "L" Upright. Only the uprights at the ends will be Closed "L" Uprights (*Figure F*).



**Figure F**