

FrameWRX™HD (High Density Moveable)

by Spacesaver®

Installation Instructions



SECTION I INTRODUCTION

SECTION II FLOOR INSTALLATION

SECTION III FIXED WALL FRAMES AND OVERHEAD GUIDES

SECTION IV MOVABLE SHELVING UNITS

SECTION V BIN RAILS AND BIN SHELVES

SECTION VI WORK SURFACES

Warning

Indicates a hazard that if not avoided, could result in death or serious injury.

NOTICE

Indicates a property damage message.

SOUTHWEST **SOLUTIONS** GROUP

business organization systems

TABLE OF CONTENTS

PAGE NO. SECTION I - INTRODUCTION

3 Tool Requirements

SECTION II - FLOOR INSTALLATION

5 Floor Preparation

7 Floor Leveling

SECTION III - FIXED WALL FRAMES AND OVERHEAD GUIDES

9 Fixed Wall Frame Weldments

15 Overhead Guide Rails

SECTION IV - MOVEABLE SHELVING UNITS

19 Moveable Frame Weldments

20 Dust Covers and Pistons

22 Handle Installation

SECTION V - BIN RAILS AND BIN SHELVES

24 Bin Rails

26 Bin Shelves

SECTION VI - WORK SURFACES

27 Work Surface Overview

28 Work Surface Installation

SECTION I INTRODUCTION

Tools Required:

Safety Glasses

Hearing Protection

Hammer Drill

- Concrete bit

Cordless Screwdriver

- Phillips Head Bit
- 9/64" Drill Bit
- 5/16 Socket Bit (for Tek screws)

Dead Blow Hammer

Tape Measure

6' Ladder

4' Level

Phillips Head Screwdriver

Wrench Set

- 9/16"

Socket and Ratchet Set

- 9/16"

Allen Wrench

- 5/32"

Shop Vacuum

Component Identification

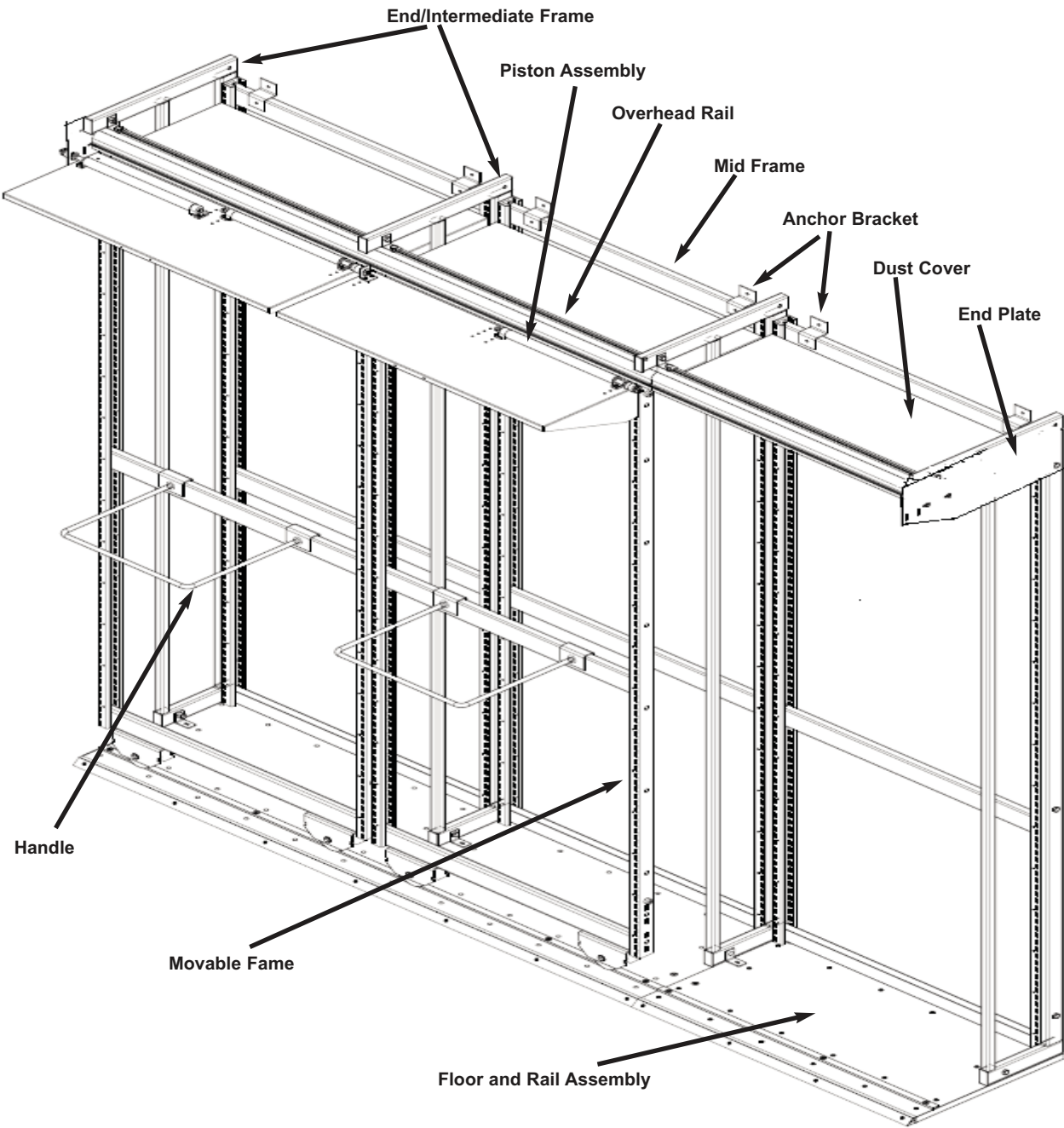

SECTION II

FLOOR INSTALLATION

Floor Preparation

STEP 1

1.1

Locate the area that the FrameWRX™ HD is to be installed. Find the high point in the floor using a level.



Note: Steps 1.2-1.7 Only apply if joining floor sections

1.2

Locate the hardware needed to connect the floor panels.

There will be 2 steel biscuits, 2 cam lock bolts, 4 cam lock nuts and 1 rail pin per floor joint.



1.3

Insert cam nuts in appropriate holes on the top of the floor near where the floor panels will butt together.



950095.001



1.4

Make sure the arrow on the cam nut faces edges to be joined.

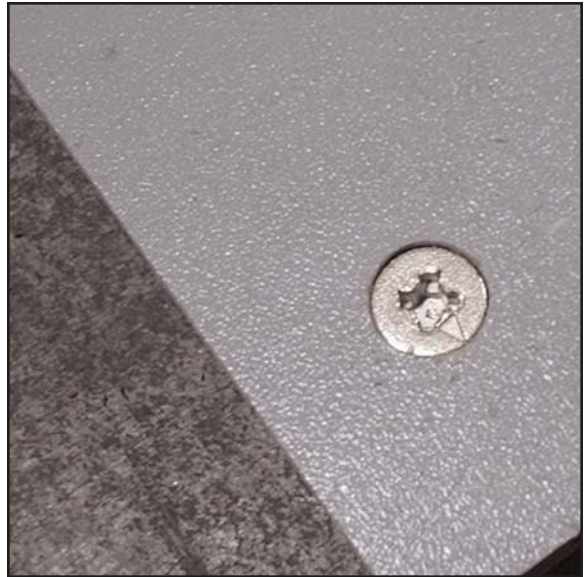

1.5

Insert cam bolts, steel biscuits and rail pins in one piece of floor.

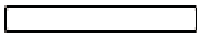

910063.003



950096.001

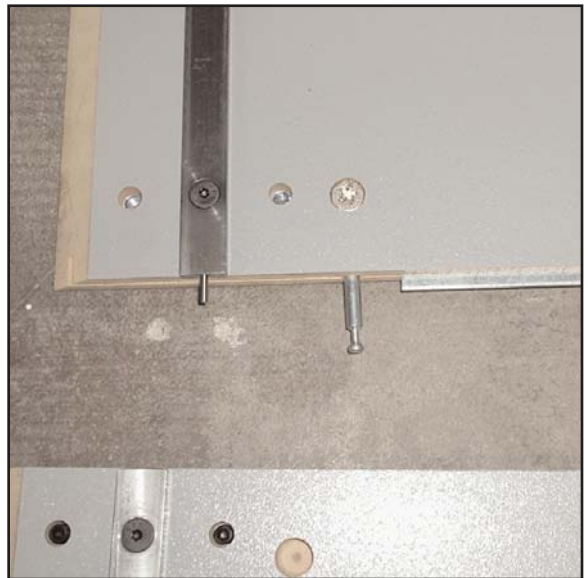

1.6

Insert cam locks into the adjoining floor panel, again ensuring the arrow on the cam nut faces edges to be joined.



1.7

Butt the 2 floor pieces together and tighten the cam locks 90 degrees clockwise.



Floor Leveling

STEP 2

2.1

Find the appropriate leveling screws needed. You will receive enough $\frac{3}{4}$ " levelers to level the entire floor, plus 10% extra 1" levelers to use if your existing floor is extremely out of level.

Levelers require a $\frac{5}{32}$ " internal hex (allen wrench) bit.



990036.001



990036.007



2.2

Use a cordless screwdriver to run levelers into the floor from the top. Raise panels $\frac{1}{16}$ " off the highest point of the floor.

⚠ Warning

Wear hearing and eye protection when using power tools.



2.3

After raising to the high point, move to the corners and insert levelers. Use a 4' level to level these.



2.4

After the corners are level, insert and level the remaining leveler locations.

NOTE: Use an allen wrench rather than a cordless screwdriver for fine-tuning to ensure floor is completely level. It may be necessary to apply some weight to the floor to keep it from moving.

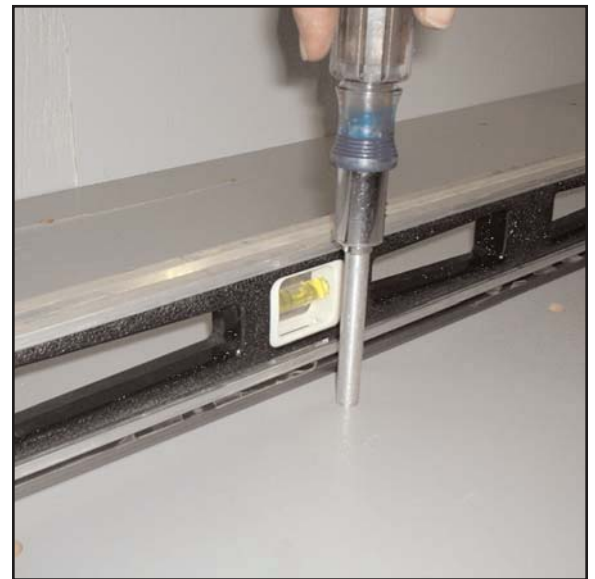

SECTION III

FIXED MID FRAMES AND OVERHEAD GUIDES

Fixed Wall Frames

STEP 3

3.1

Locate the end/intermediate frames and the fixed Mid frame weldments.

(NOTE: The end/intermediate frames are the same part. They serve as both the end frames, and the link between frame weldments.)



Frame Weldment

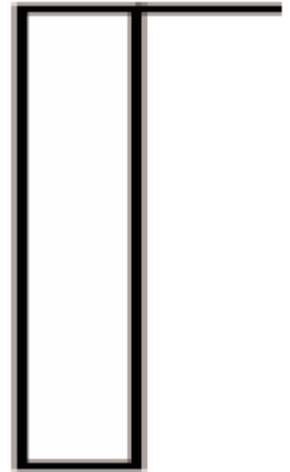

End/Intermediate Frame

3.2

Take one end frame and butt it up against the frame weldment.

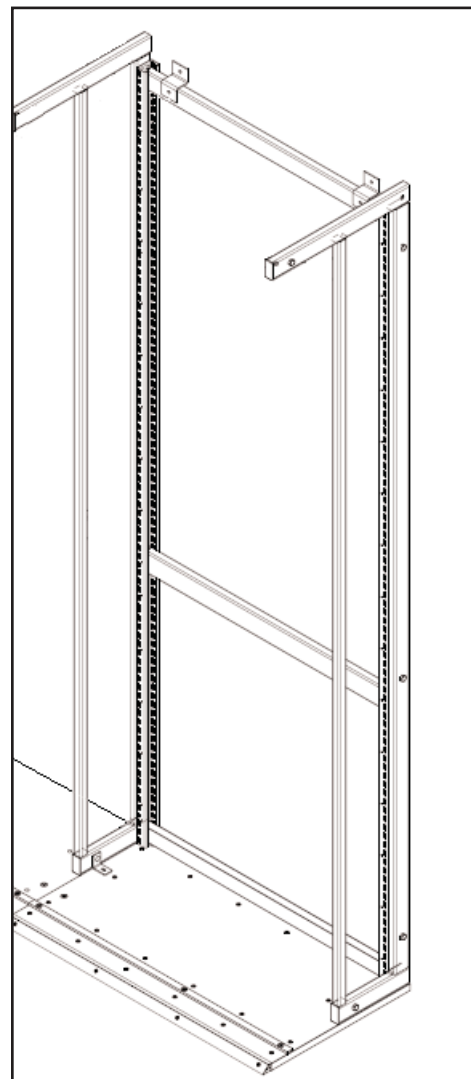

3.3

Locate the mounting hardware for the frames. These are 3/8"x 1-3/4" bolts and nuts.

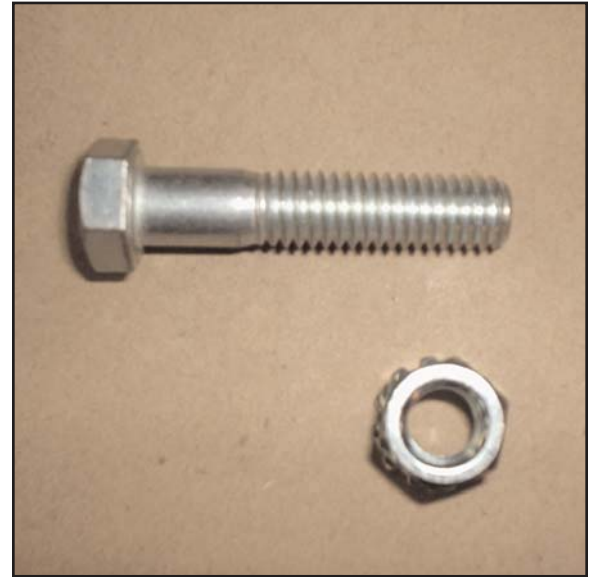
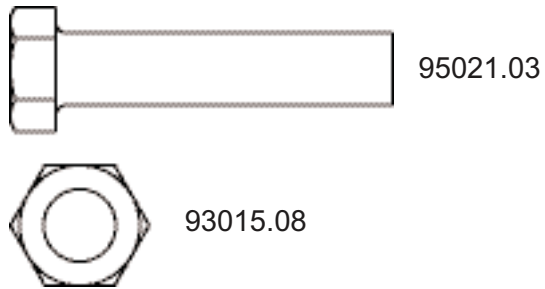

3.4

Insert the 3/8"x1-3/4" bolt through the outside of the end frame, through the frame weldment at the middle and lower positions.

The bolt head must be on the outside of the end frame. Attach nut. Do this in all three holes throughout the length of the end frame.

NOTE: At this point only hand tighten these bolts. This will make the process of attaching the back frames to the floor easier.



3.5

Locate the End Plates. One will be required for each end.

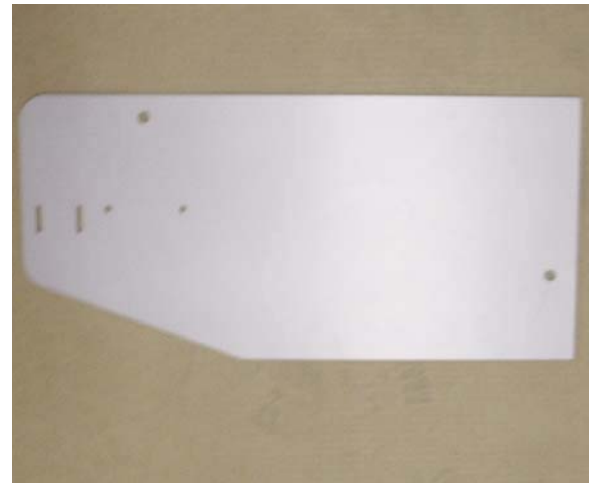

3.6

Insert bolt thru End Plate, End Frame and Mid Frame at top location. Hand tighten nut.



3.7

Locate the intermediate frames. Sandwich the intermediate frame between the weldment you just installed and the next weldment. While holding in place, insert the 3/8"x1-3/4" bolts through both frame weldments and the intermediate frames. Place nuts on the ends of these 3 bolts, and hand tighten them.

3.8

Repeat previous steps the entire length of the floor, finishing with an end frame at the end.



3.9

Attach the anchor clips with 3/8"x1-3/4" bolts and nuts. The end frames use 1 anchor clip, while the intermediate frames use 2.

NOTE: The slot side of the anchor clip must be on the floor.

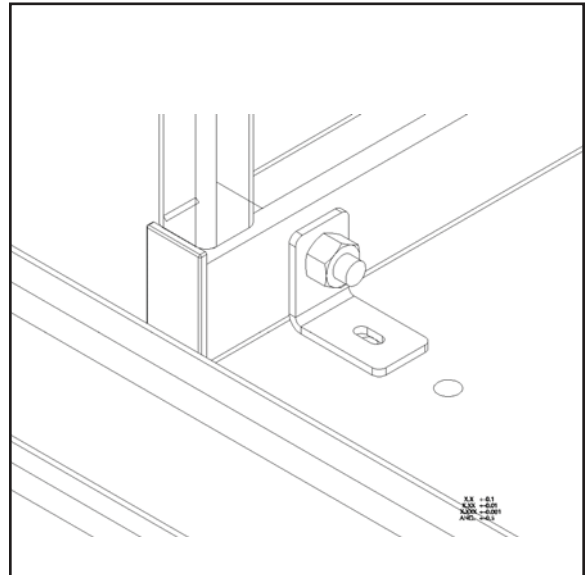
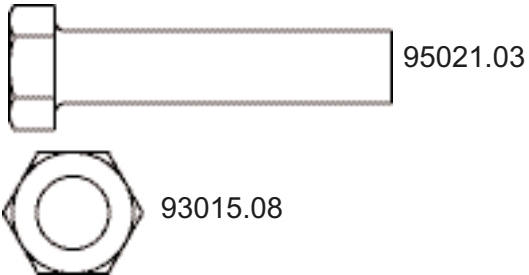

3.10

Make sure that the bolt head is on the outside of the end frame for overall appearance. Hand tighten only.

Bracket # 401498.001

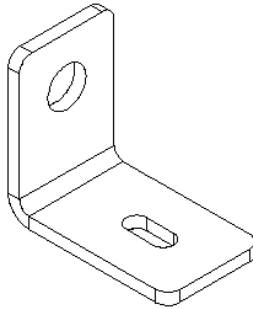

3.11

Anchor the intermediate frames through the floor assembly into the subfloor with a minimum 3/16" anchor. Follow the manufacturers instructions. We do not provide anchors as requirements or codes may vary.

⚠ Warning

Wear hearing and eye protection when using power tools.

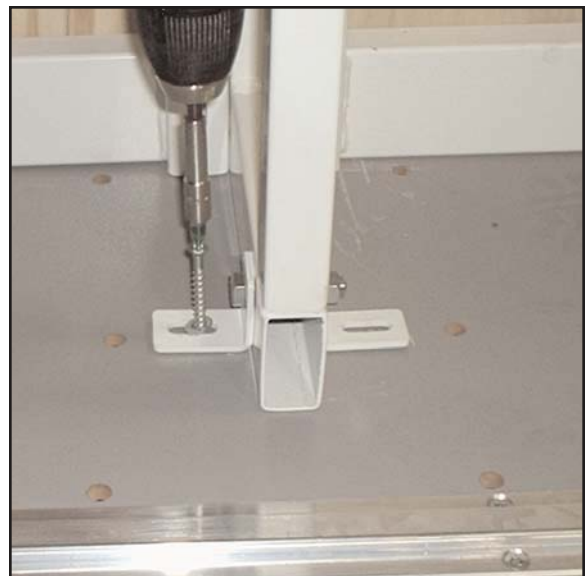

3.12

After all the anchor screws are in place, tighten all the bolts holding the anchor clips to the frames. When these are tightened, you can finish tightening all the bolts on the frames.



3.13

After all bolts are tightened, insert the black plastic end caps. There are 2 caps per end and intermediate frame, one located at the top and one at the bottom.

Cap part # 780043.001

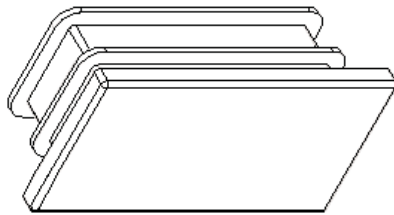

3.14

When finished, the end caps should look like this.



3.15

Locate the wall anchor brackets. These can be placed anywhere along the top of each weldment.



3.16

Drill appropriate holes and bolt in the wall brackets.

NOTE: Fastening hardware is not provided as stud materials vary. Shims may also be required to accommodate the inconsistencies between the back frame and the wall. Washers work well, but are not provided.

NOTICE

Every frame must be anchored into a solid mounting location, such as a wall stud.

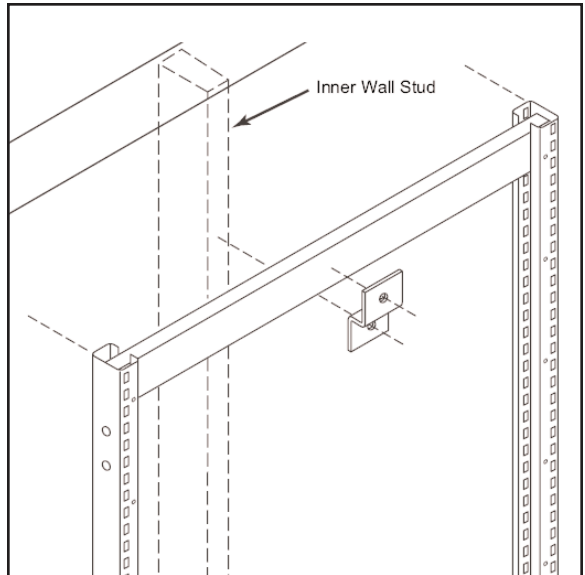

3.17

Check all frames for plumb.

Tighten all hardware at this time.



Overhead Guide Rails

STEP 4

4.1

Locate the aluminum overhead guide rails, square-nuts, and connecting pins.

4.2

Insert square-nuts in the overhead guide rail. Each guide rail should have one square-nut for each end frame and two splice nuts for each intermediate frame. Start with one nut 3" from the left and place 2 every 30" of rail section, ending with a square nut 3" from the right.



930091.001

4.3

Insert the (2) 3/16" dia. x 2.00" long connecting pins on one end of the rail where it will be used to connect the other rail.



910070.001

4.4

Locate the hardware for bolting the guide rails to the frames. The 2 end frames will get (1) bolt, keps nut, and angle bracket. The intermediate frames will get (2) angle brackets, (1) bolt, and keps nut.

Bracket # 401616.001

Bolt # 95021.02

Nut # 93015.08

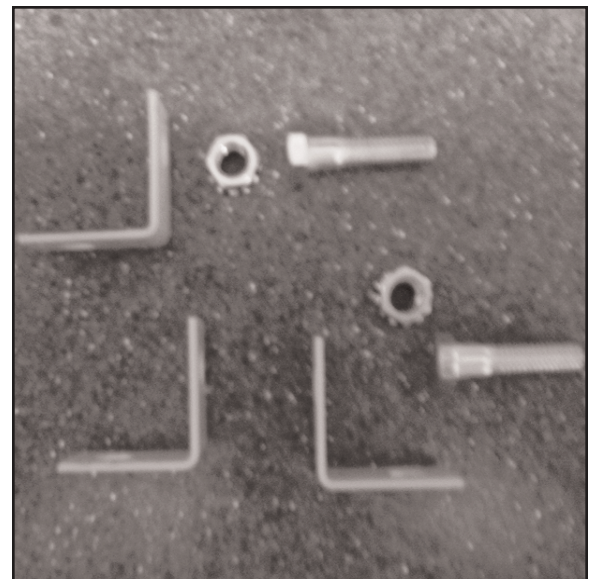
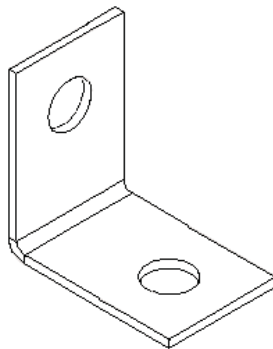

4.5

Place bolt thru End Plate, End Frame and Angle Bracket. finger tighten nut at this time.



4.6

Install two Angle Brackets onto each Intermediate Frames. Do not tighten hardware at this time.



4.7

Lift the first overhead rail section into place.



4.8

Insert a bolt thru the bottom of the angle into the square-nut in the overhead guide. Do not tighten hardware until instructed to do so.

Bolt # 95021.08

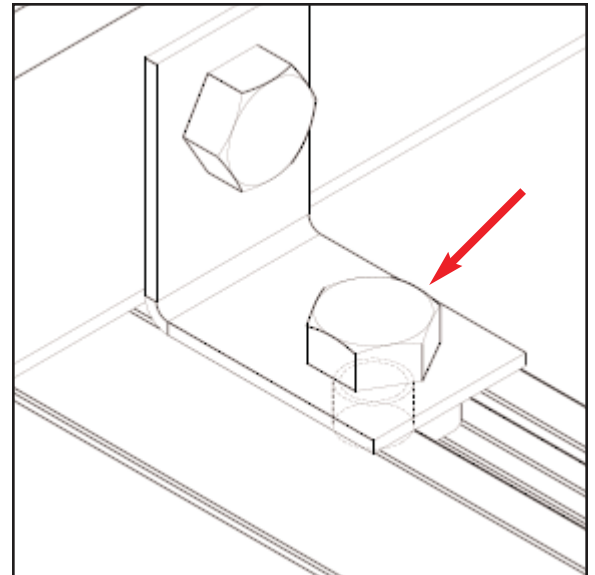

4.9

Each additional Top Guide Rail will be reinforced with pins at each splice. Install these into one rail, then slide into the adjacent rail.

4.10

When you are satisfied with the position of the rail, tighten all bolts on the angles and overhead guide rail.



4.11

Locate the magnet assemblies.

NOTE: Magnet assemblies come as part of the air shock/piston assembly kit, which includes both the magnet and piston assembly. Part # 550501.001



4.12

Attach the magnets to the end caps with the supplied nut and washers. The magnet needs to be facing towards the inside of the system. Assemble in this order:

1. Magnet
2. Rubber Washer
3. End Plate
4. Rubber Washer
5. Flat Washer
6. Machine Screw Nut
7. Spring Lock Washer
8. Machine Screw Nut

NOTE: The end plates for the right side will have the magnets placed in the back vertical slot. The magnets on the left side will be placed in the front vertical slot. These will match up with the piston assemblies on the overhead dust covers.



4.13

Using two #12 X 1" tech screws, screw the End Plate to the Top Rail.

Repeat on each end.



96060.01

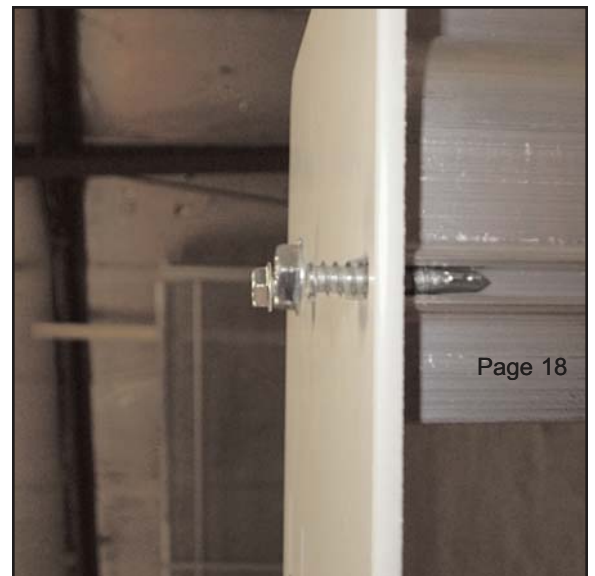

SECTION IV

MOVABLE WELDMENTS

Moveable Frame Weldments

STEP 5

5.1

Locate the moveable frame weldments. These will have the wheel sections attached. All moveable frames will have rubber bumpers on both sides of the top and bottom of the frames.

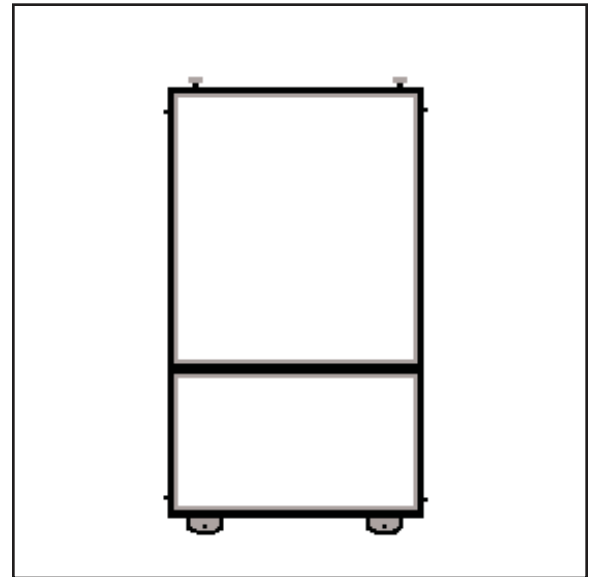

5.2

The easiest way to install the moveable frame is to tilt the frame, inserting the guide wheels into the overhead guide rail. Lift the frame up and engage the bottom wheels onto the floor rail. Slide back and forth a couple of times to ensure that the wheel section is sitting properly on the rail. Repeat this step with the other moveable frame sections.



Dust Covers and Pistons

STEP 6

6.1

Locate the dust covers. The dust covers without piston assemblies will be used as canopy tops on the fixed frames. The dust covers with the pre-installed piston assemblies will be used for the moveable frames.

NOTICE

On the moveable frames, the far left dust cover will have 2 piston assemblies, while the rest will only have 1.

6.2

Locate the dust cover hardware. Each dust cover requires 4 1/4-20 UNC bolts and 4 1/4-20 UNC keps nuts.



93015.02



96057.04

6.3

Place the 1/4-20x1" bolt through the hole on the rear of the dust cover. Lift the dust cover and place on the frame weldment, threading the keps nut on the inside of the weldment post. Use the third hole from the top on the frame weldment for the top bolt of the cover. Only hand-tighten. Do this with the other three bolts & nuts. When all 4 are in, adjust so the dust cover is level. Repeat this process on all weldments.



6.4

Repeat this step on the remainder of the frames.

NOTICE

The location of the piston on the dust covers will be staggered. Make sure each piston hits the adjacent stops.

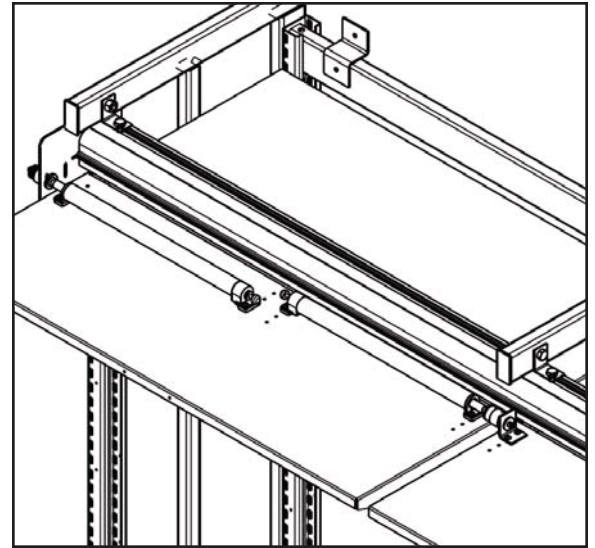

6.5

When all the dust covers are installed, you can adjust the tension on the piston assemblies. To adjust, loosen the knurled jam nut. Turn the screw into the piston for a firmer piston. For a softer piston, turn the screw outward from the piston. When the desired setting is reached, tighten the lock nut on each piston assembly.

Roll frames back and forth to test piston settings and readjust as necessary.

NOTICE

Once system is fully loaded roll frames back and forth to check piston settings. Re-adjust pistons as necessary to provide cushioned stopping.

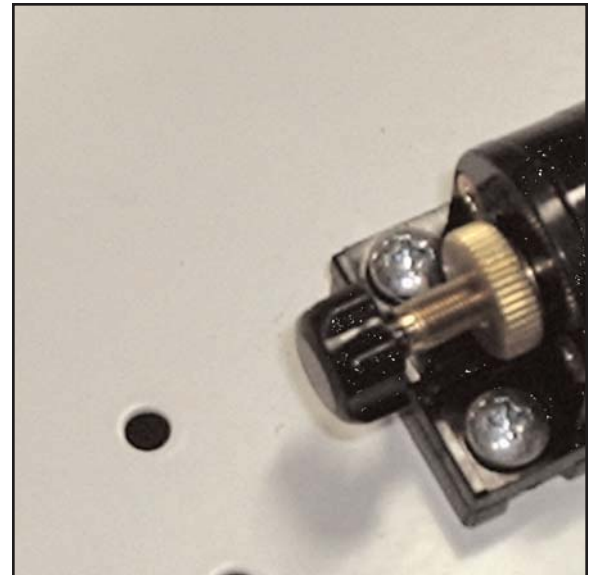

Handle Installation

STEP 7

7.1

Locate the handle and 4 #10 tek screws.

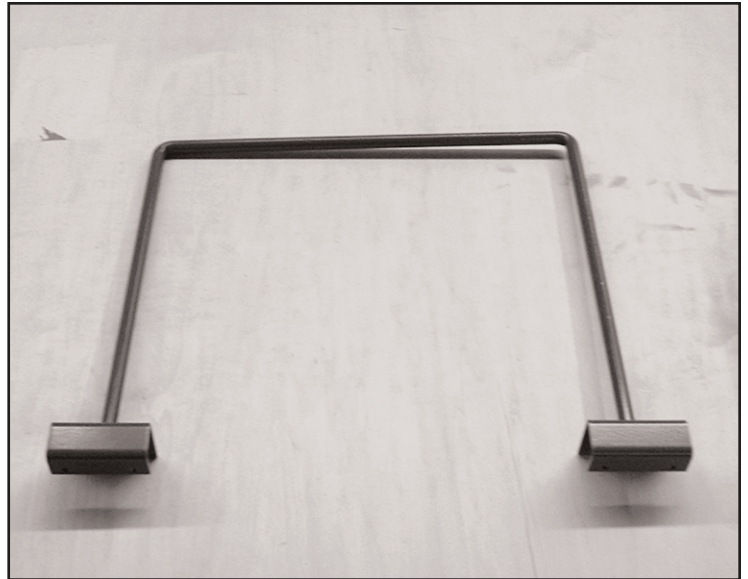

7.2

Hang the handle in the center of the middle spreader on each moveable frame.



7.3

Drive (2) self tapping tek screws thru the pre-drilled holes on the handle into the back of the bar spreader.

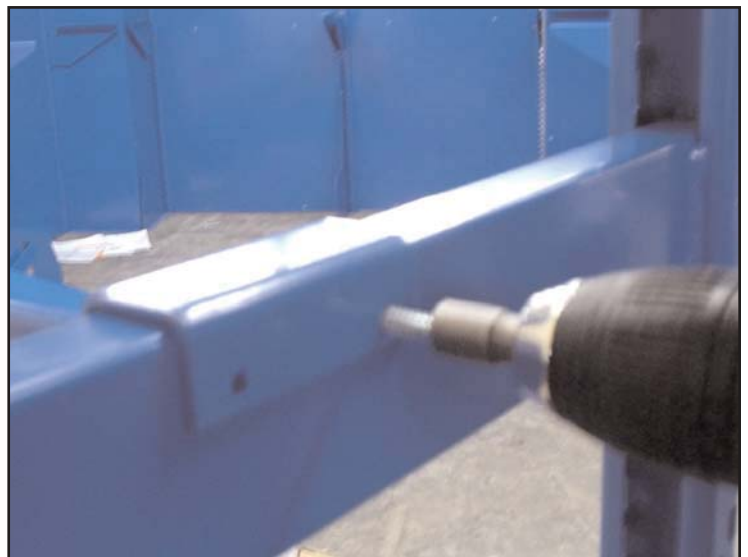

7.4

Ensure that the handle is secure before using.



SECTION V

EZ RAILS AND BIN SHELVES/TRAYS

EZ Rail Installation

STEP 8

8.1

Locate EZ Rails.



Note: EZ Rails have 3 mounting tabs. This allows the rail to be adjusted from a normal vertical position to one that angles down approximately 18 degrees.



8.2

Vertical Position

Use the top 2 tabs on the EZ Rail and insert into the slots on the welded frame. Make sure that both sides are evenly spaced in height.

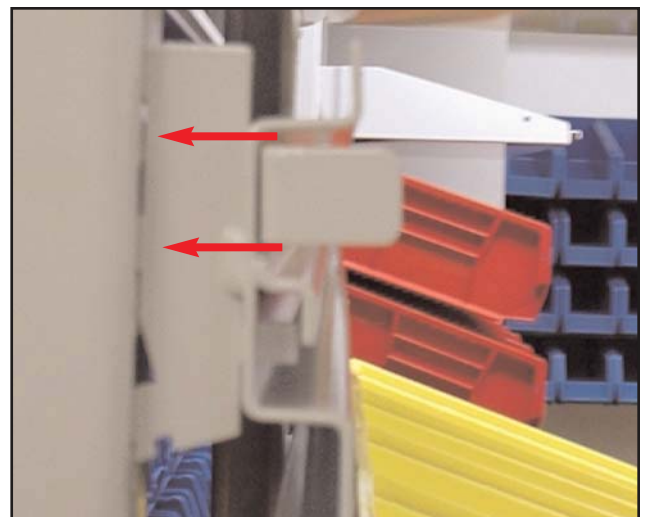

8.3

Angled Position

To slant the EZ Rail forward, use the bottom 2 tabs. Insert them into the slots on the welded frame.

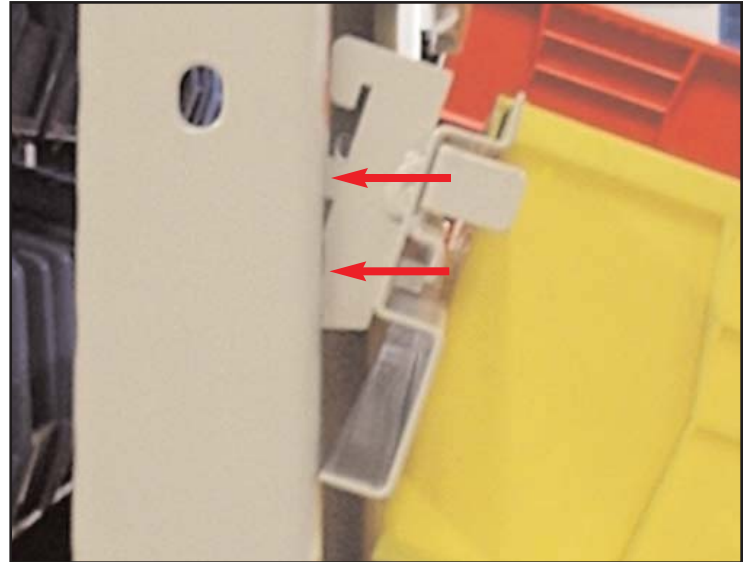

8.4

EZ Rails can be used to accommodate slat wall pegs. To install, hook the top of the peg bracket up-and-in the top guide of the EZ Rail.

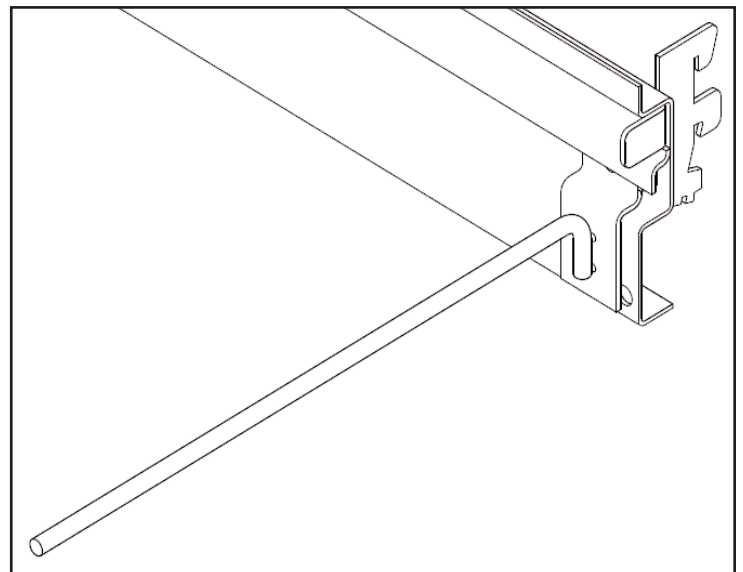

8.5

Plastic storage bins hang on the top lip of the EZ Rail.

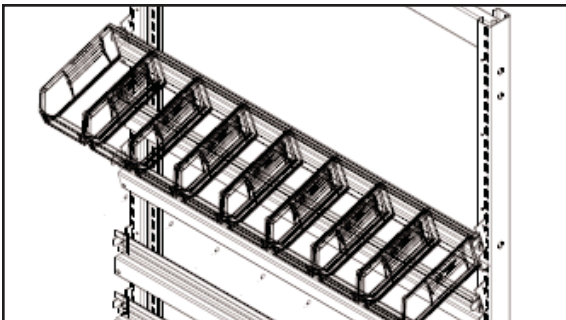

Bin Shelf/Tray Installation

STEP 9

9.1

Locate bin shelves/trays.

Note: Bin shelves/trays have 3 mounting tabs. This allows the bin rail to be adjusted from a normal vertical position to one that angles down approximately 18 degrees.



9.2

Vertical Position

Use the top 2 tabs on the bin shelf/trays and insert into the slots on the welded frame. Make sure that both sides are evenly spaced in height.

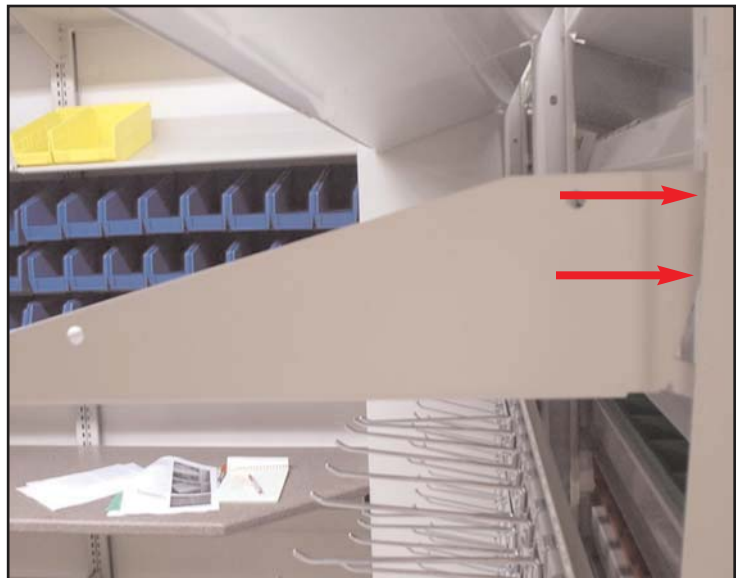

9.3

Angled Position

To slant the bin shelf/tray forward, use the bottom 2 tabs. Insert them into the slots on the welded frame. Make sure that both sides are evenly spaced in height.



SECTION VI WORK SURFACES

Work surfaces

These come in 2 standard materials-
laminite and non-porous

There are four different configurations
(double, rectangle, right, left chamfer)

Work Surfaces that span across 2
frames require that 2 bracket kits (4
brackets) be used



Double Chamfer

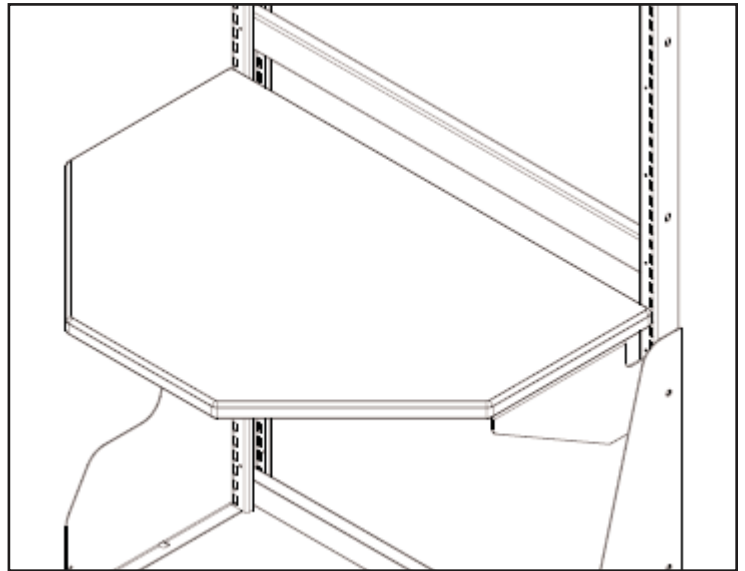

Rectangle

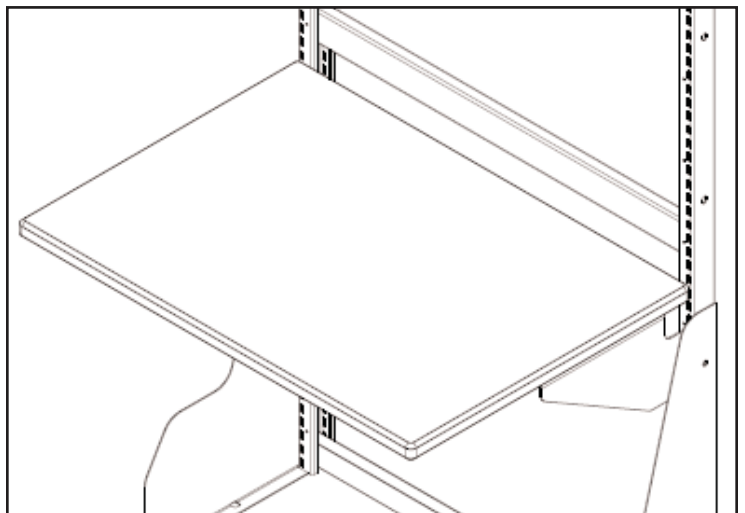

Right Chamfer

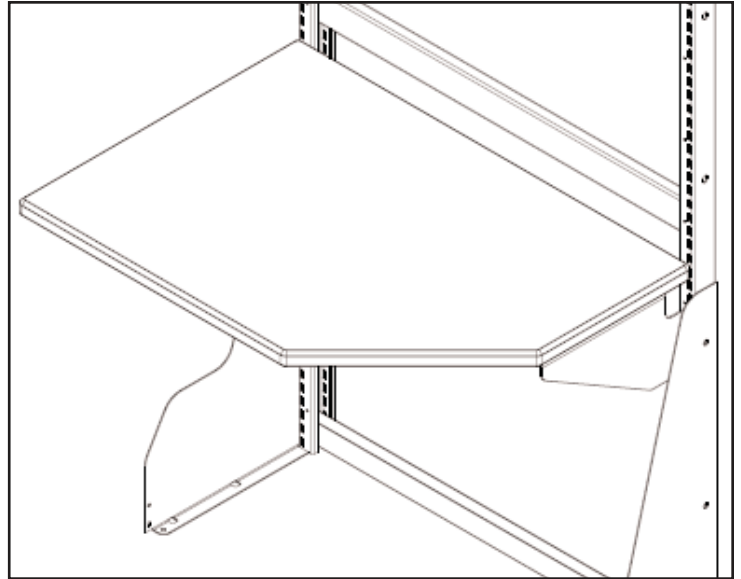

Left Chamfer

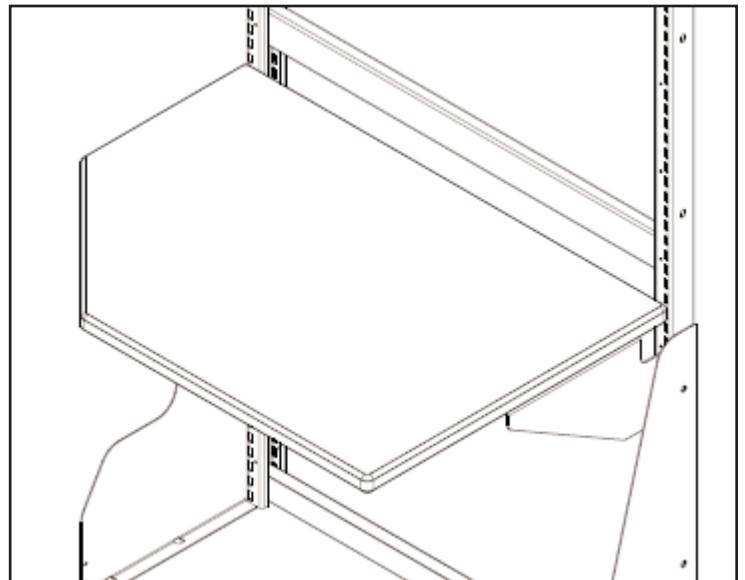

Step 9.1

Insert work surface brackets into the slots in the welded frame. make sure that you place the brackets the same distance from the floor on all frames so the work surface height is consistent.

Left and right brackets are different. Point the mounting tabs inward.

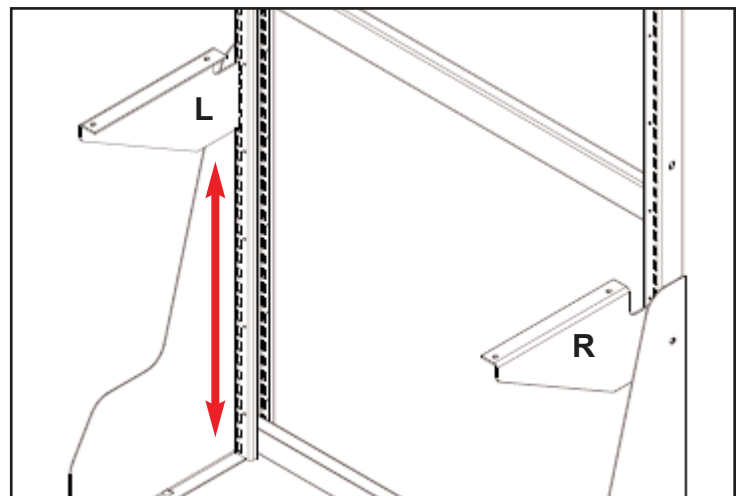

Step 9.2

Set the work surface on top of the brackets. Drive 2 self tapping screws thru the pre-drilled holes on the brackets, into the underside of the work surface panel.



Step 9.3

Repeat process on other work surfaces. Make sure that work surfaces line up with each other.

